



DRAFT DESIGN REVIEW GUIDELINES

CITY OF SUMTER, SOUTH CAROLINA



PAGE LEFT INTENTIONALLY BLANK

TABLE OF CONTENTS

ACKNOWLEDGEMENTS—5

CHAPTER 1: INTRODUCTION—7

BENEFITS OF HISTORIC PRESERVATION	9
OVERLAY DISTRICTS & DESIGN REVIEW	9
HISTORICAL OVERVIEW	14

CHAPTER 2: UNDERSTANDING HISTORIC CHARACTER —17

RESIDENTIAL STYLES	19
COMMERCIAL AND INSTITUTIONAL STYLES	25

CHAPTER 3: PLANNING A PROJECT—29

STEPS TO CONSIDER FOR A SUCCESSFUL PRESERVATION PROJECT	31
VISIBILITY AND LEVEL OF REVIEW	32
INCENTIVES	32

CHAPTER 4: GUIDELINES FOR REHABILITATION—35

ROOFS	37
FOUNDATIONS	39
EXTERIOR WALLS: MASONRY	40
EXTERIOR WALLS: SIDING	42
ARCHITECTURAL DETAIL AND ORNAMENTATION	44
WINDOWS	45
SHUTTERS	48
DOORS	49
PORCHES	52
STOREFRONTS	55
PAINT	60
SIGNS & AWNINGS	62

CHAPTER 5: SITE DESIGN—69

TREES AND PLANTINGS	71
FENCES AND WALLS	72
DRIVEWAYS, WALKWAYS AND RAMPS	74
PARKING AREAS	76
LIGHTING	77
OUTBUILDINGS AND ACCESSORY STRUCTURES	78
MECHANICAL AND UTILITIES SCREENING	79

CHAPTER 6: NEW CONSTRUCTION & ADDITIONS—81

COMMERCIAL PROPERTIES	83
RESIDENTIAL PROPERTIES	92

CHAPTER 7: RELOCATION & DEMOLITION—105

RELOCATION	107
DEMOLITION	109

PAGE LEFT INTENTIONALLY BLANK

ACKNOWLEDGEMENTS

The activity that is the subject of this publication has been financed in part with Federal funds from the National Park Service, U.S. Department of the Interior, and administered by the South Carolina Department of Archives and History. However, the contents and opinions do not necessarily reflect the views of policies of the Department of the Interior, nor does the mention of trade names or commercial products constitute endorsement or recommendations by the Department of the Interior.

This program receives Federal financial assistance for identification and protection of historic properties. Under Title VI of the Civil Rights Act of 1964, Section 504 of the Rehabilitation Act of 1973, and the Age Discrimination Act of 1975, as amended, the U.S. Department of the Interior prohibits discrimination on the basis of race, color, national origin, disability or age in its federally assisted programs. If you believe you have been discriminated against in any program, activity, or facility as described above, or if you desire further information, please write to:

Office for Equal Opportunity
National Park Service
1849 C Street, NW
Washington, D.C. 20240

City Council

Joseph T. McElveen, Jr., Mayor
Steve Corley
Ione J. Dwyer
Robert A. Galiano
Calvin K. Hastie, Sr.
Thomas J. Lowery, Mayor Pro Tem
David Merchant

Historic Preservation Design Review Committee

J. Grady Locklear, Chair
Billy F. Taylor, Vice-Chair
R. Scott Bell
William A.W. Buxton
Jean W. Whitaker
Sharon B. Clark
Julie M. Herlong

City of Sumter Staff

Deron L. McCormick, City Manager
George K. McGregor, Planning Director
Helen M. Roodman, Senior Planner
Eric Shytle, General Counsel



HILL
STUDIO

120 West Campbell Ave.
Roanoke, Virginia
540 342 5263
www.hillstudio.com

PAGE LEFT INTENTIONALLY BLANK

1

INTRODUCTION

The City of Sumter established the Downtown Historic District and the Hampton Park Design Review District to help preserve the city's historic character and unique sense of place. As the value of a historic district is cumulative, the whole being greater than the sum of its parts, it is important to preserve the architectural components that give a district its overall historic character and visual quality. To this end, the City has authorized the Historic Preservation Design Review Committee (HPDRC) to review major exterior alterations, additions, demolitions, or relocations of buildings, as well as new construction proposed within the two districts.

The Sumter Design Review Guidelines intend to assist property owners in planning for the appropriate treatment of their historic buildings and to guide the HPDRC in their review of proposed projects. Additionally, this document provides information to assist property owners in understanding the architectural style of their building and ways to maintain the building components to preserve its historic character. Rather than a rigid set of restrictions, these guidelines should be viewed as guiding principles that, when followed, will result in sound historic preservation practices.

It is the hope of the City of Sumter and the HPDRC that these design review guidelines will assist property owners in the development of compatible and appropriate treatments and designs for the continued use of buildings in the two historic districts. Through the design review process and the use of the guidelines, the City and its property owners can be good stewards of Sumter's historic districts. Continuing to use historic buildings while preserving their unique architectural qualities will preserve Sumter as a wonderful place to live, work, and visit.

PAGE LEFT INTENTIONALLY BLANK

1.1 BENEFITS OF HISTORIC PRESERVATION

Historic preservation is a powerful tool used by municipalities nationwide to maintain their unique character and identity. Collectively, the buildings in a historic district represent the cumulative efforts and achievements over time of people forming a community; therefore, their preservation can help to strengthen that sense of community and inherent quality of life today. The preservation of local historic districts can protect and increase property values, enhance a locality's identity, and improve residents' sense of connection to their community. By preserving a community's unique sense of place, historic districts can also serve as tools to promote heritage tourism and economic development.



1.2 OVERLAY DISTRICTS & DESIGN REVIEW

Recognizing the benefits of historic preservation, the City of Sumter established two overlay districts to assist in preserving and protecting the historic character of the Central Business District and the Hampton Park neighborhood. Identified in the City of Sumter Zoning and Development Standards Ordinance as the Downtown Historic District and the Hampton Park Design Review District, the properties within these two overlay districts are subject to design review. The map on page 11 shows the boundaries of the overlay districts. The Sumter Planning Commission GIS database also identifies affected properties.

PURPOSE OF DESIGN REVIEW

The City of Sumter created the Downtown Historic District and Hampton Park Design Review District to promote the educational, cultural, economic, and general welfare of the public by providing a mechanism for the identification, recognition, preservation, maintenance, and enhancement of existing historic and architecturally valuable structures, properties, and neighborhoods. These places serve as a visible reminder of the social, cultural, economic, political and architectural history of the City and County of Sumter. The purpose of the design review process is to preserve the overall architectural character and visual qualities of the historic districts. The ultimate goal of the design review process is to allow active use and adaptation to properties within historic districts while maintaining the architectural integrity that reflects the district's history and significance.

OVERLAY DISTRICTS

Sumter City Council designated Hampton Park as a local historic district in 1979. Identified as the Hampton Park Design Review District in the Ordinance, the overlay district encompasses more than six city blocks surrounding Memorial Park. The district boundaries are Church Street to the east, Hampton Avenue to the south, McQueen Street to the west and Calhoun Street to the north. Approximately 120 acres in size, the district contains 268 individual parcels. Primarily a residential neighborhood, the district contains a broad range of architectural styles popular in the late-nineteenth and early-twentieth centuries, including Queen Anne, Folk Victorian, Craftsman, Colonial Revival, and Spanish Colonial Revival. Lots are relatively large with generous and uniform setbacks. Historic fencing or low walls often define the property lines. Mature trees and other plantings line the streets and enhance the yards.

The Downtown Historic District includes the entire extent of the Central Business District. The overlay district, which includes the original one-and-one-half-mile square around the courthouse, consists primarily of commercial and institutional buildings dating from the early-nineteenth century to the present. Typically of brick construction, these buildings are designed in a variety of styles—including Italianate, Romanesque Revival, Victorian, Neoclassical, Colonial Revival, and Commercial—with storefronts or public entrances at street level and decorative cornices above.

A portion of the Downtown Historic District overlay was listed in the National Register of Historic Places as the Sumter Historic District in 1975. The district is approximately 35 acres in size and centered on Main Street between Canal and Caldwell streets, extending less than one block to the east and west of Main Street. Hampton Park has been determined eligible for the National Register of Historic Places, but it has never been formally nominated.

A National Register designation is an honor bestowed on historic properties to recognize their historic value and to encourage continued stewardship. It does not restrict property owners in any way, but does offer the benefits of several federal and state programs, including tax credits for rehabilitation. While a property or district may be listed on the National Register, only a local overlay district designation places design review restrictions on private owners.

HISTORIC PRESERVATION DESIGN REVIEW COMMITTEE

In 1996, the City of Sumter established the Historic Preservation Design Review Committee (HPDRC) as a means to protect the historic and architectural integrity of the overlay districts. The City authorizes the HPDRC to review all applications for major exterior alterations, additions, demolitions or relocation of historic buildings, as well as designs for new construction proposed in the two districts. Upon approval of the application, the HPDRC will issue a Certificate of Appropriateness (COA) for the proposed work as part of the building permit process. The HPDRC, as provided by the ordinance, is composed of individuals with diverse professions and experiences that can view proposed designs from many different perspectives and consider the interests of all residents.

DESIGN REVIEW GUIDELINES

The Sumter Design Review Guidelines provide the HPDRC with a means to review all requests with an established set of standards. The organization of the guidelines is by treatment type or project and then addresses each component of the building and its design with recommended best practices. The guidelines provide for consistency in the design review process by removing subjectivity and personal preference. The HPDRC will follow these guidelines closely, but it is empowered to take into account other considerations, including, but not limited to, the condition of the property, its consistency with neighboring uses, previous use of the subject property, and prevailing uses within the historic district at large.

For property owners, the guidelines provide useful rehabilitation and construction information to assist in understanding the architectural character of their historic buildings and in planning for their appropriate treatment. Additionally, the design guidelines provide the property owner with an understanding of the design review process and insight into the HPDRC's requirements to approve a project.

WORK THAT REQUIRES DESIGN REVIEW

The overlay zoning requires review of changes to the exterior appearance of any building within a designated overlay district. A project must adhere to the criteria in the City of Sumter Zoning and Development Standards Ordinance and the Sumter Design Review Guidelines in order to be approved. Work that requires a COA includes most exterior alterations, additions, demolition or relocation, and new construction. Ordinary maintenance generally does not require a COA unless it would alter the exterior of the building. While the HPDRC hears most applications, Planning Department staff may issue a general certification for appropriateness for specific kinds of alterations. A list of these general certifications are in Article I, Section O of the City of Sumter Zoning and Development Standards Ordinance.

APPLICATION FOR CERTIFICATE OF APPROPRIATENESS

An applicant initiates the design review process by submitting an application for a COA through the office of the Zoning Administrator. Applicants can request application forms at the Planning Department located at 12 West Liberty Street or online at www.sumtersc.gov.

Applications for exterior alterations, additions, demolition or relocation, as well as new construction should include any materials that add to the understanding of an application, including architectural plans, a site plan, photographs, and specifications, or samples for colors and materials. For minor changes, nothing more may be required than to provide a detailed description of the work to be undertaken in the application. Applicants should submit the application with supplementary materials to the Zoning Administrator a minimum of 22 days prior to the HPDRC meeting. The Zoning Administrator will review all applications for completeness prior to consideration by the HPDRC. The applicant will be contacted if additional information is necessary. Once reviewed, the staff will make a recommendation to the HPDRC.

HPDRC MEETINGS

Meetings of the HPDRC occur on a monthly basis. The HPDRC establishes meeting dates and times at the first meeting of each year. Applications must be complete and submitted 22 days prior to a meeting to be placed on the agenda. The City advertises all applications for a COA in the *Sumter Daily Item* at least 15 days prior to the meeting and posts properties with a public notice so the public may attend meetings and comment on the request.

The HPDRC may approve, approve with conditions, or disapprove an application. The HPDRC also has the right to delay action on an application in order to gather additional information or documentation. If approved, the HPDRC will grant a Certificate of Appropriateness, allowing the applicant to continue with the approved work. If disapproved, the applicant can appeal the decision of the HPDRC to the Circuit Court. Applicants must file all appeals within 30 days of the HPDRC's decision.

OTHER APPLICABLE REGULATIONS

All properties are subject to building codes and the City of Sumter Zoning and Development Standards Ordinance. The Building Official or Zoning Administrator will decide any disputes or discrepancies between building codes and these design guidelines.

WORK UNDERTAKEN WITHOUT A COA

If a property owner initiates work without the prior approval of the HPDRC, the City will issue a stop work order. The property owner will then be required to explain the work and the reasons why they did not obtain a COA. Completion of the design review process may then be required. Once the design review process is completed, the property owner must follow the HPDRC's requirements. If an owner does not meet these requirements, they may face fines and/or an order to restore the property back to its original condition.

1.3 HISTORICAL OVERVIEW

The City of Sumter was originally part of Craven County, established in 1682, under the tenure of the Lords Proprietors of South Carolina. Almost a century later, in 1769, Craven County became part of the Camden Judicial District. In 1783, the Camden District was divided into seven counties, two of which were Claremont and Clarendon. Settlement in these counties consisted of two small villages. In 1792, land taken from Claremont and Clarendon Counties was used to form Salem County. Eight years later, in 1800, the state legislature merged Claremont, Clarendon, and Salem Counties to form the Sumter District and authorized the construction of a district court house. The state appointees who oversaw the establishment of the new courthouse chose as its site a plantation owned by John Gayle. The Gayle Plantation site located near the center of the district became the nucleus for the village of Sumterville. The Sumterville settlement grew slowly during the first part of the eighteenth century, and through the 1830s numbered only twenty houses. In 1845, the village was incorporated as a square with side's one-and-one half miles long with a centered courthouse. The layout of the streets in the downtown area today remains much as it was in 1845.

As was the case with many backcountry settlements, the advent of the railroad opened the way to economic prosperity. A section of the Wilmington and Manchester Railroad (W&M RR), connecting Sumterville to the Camden Branch, opened in 1852 and acted as the catalyst for the town's first economic boom. The impact of the railroad on Sumterville, which in 1855 changed its name to "Sumter," was significant. The decade of the 1850s saw unprecedented growth in the construction of new residential, commercial, and warehouse buildings; the town drained its streets and its residents established the first bank. Many fine homes were built during the period between the advent of the railroad and the outbreak of the Civil War.

The Civil War had a profound impact on all of South Carolina, including the town of Sumter. However, the economic structure of the area surrounding Sumter, comprised primarily of small farms rather than large plantations dependent on slave labor, provided a better base for recovery than existed in many other counties. The Camden Branch of the South Carolina Railroad reopened in 1867. The Wilmington, Columbia, and Augusta railroad, which connected Sumter directly to Columbia, opened in 1871. By 1889, the Sumter Electric Light Company provided electricity to the town with the construction of a power plant near the railroad depot.

Sumter's economy continued to diversify during the late nineteenth and early twentieth centuries. With six new railroad lines serving the county by 1900, Sumter increased its industrial base to include: brick manufacturing; flour, lumber, and gristmills; a turpentine factory; and other factories associated with lumber and cotton products.

By the turn of the twentieth century, the town of Sumter began to grow beyond the original one-and-one half mile square around the courthouse. Businesses in the commercial center boasted a wide range of stores, including an insurance agency, two printing stores, various general merchandise stores, two drug stores and liquor stores, a millinery, and a Masonic Hall. Prominent additions included the grand new First Presbyterian Church, the Sumter Iron Works, and an unusual housing development of four precise rows of four houses each at the corner of Canal and Sumter Streets.

The town also expanded during this period with the development of two residential neighborhoods on either side of Liberty Street to the west of the commercial downtown. Known today as Hampton Park, the area around Memorial Park features prominent houses built by some of the wealthiest residents of Sumter. The styles of houses in this neighborhood reflect what was appropriate for members of this "up-and-coming urban elite." Houses surrounding Memorial Park provide examples of what were considered in the late-nineteenth and early-twentieth centuries the latest styles: Queen Anne, Craftsman, Colonial Revival, and Spanish Colonial Revival.

Sumter enjoyed another boost to its economy in 1941, when the federal government opened an Army Air Corps training base, which would become Shaw Air Force Base. The large number of neighborhoods, houses, and apartments dating to the late 1940s and 1950s offer testament to the influx of military personnel and families associated with Shaw Air Force Base and its continued impact on the city of Sumter.

Sumter's architectural development mirrors the city's economic development and its overall patterns of growth. With the exception of a small sample of modified Greek Revival houses built prior to the Civil War within the original courthouse village, most of the older structures date from the late-nineteenth and early-twentieth centuries, the period that coincides with the surge of growth brought about by the railroads and new manufacturing enterprises. As the town expanded, houses were built in residential neighborhoods that were distinct from the commercial center of town. Two residential neighborhoods, including Hampton Park, developed during this period on either side of Liberty Street. The architectural styles of both the commercial and residential buildings, particularly in the late nineteenth century, featured an eclectic mix of recognizable styles, many of which were loosely derived from European styles. By the early twentieth century, the emphasis had shifted to more identifiably "American" styles such as Craftsman and Colonial Revival. The second wave of prosperity and the accompanying explosion of residential construction spurred by the presence of Shaw Air Force Base resulted in a large number of post-World War II housing, both single and multiple family, in a variety of styles. Located in new suburban developments, the designs of these post-World War II buildings, while eclectic, were less influenced by local or historical precedents than national trends in modern materials, construction and mass production for affordable housing.

The City of Sumter today contains a rich mix of commercial, institutional, industrial and residential buildings in a wide range of dates and styles that represent its development from the early nineteenth century through the twentieth century. In recognition of the city's historical significance as represented by its historic buildings, the Sumter Historic District was listed on the National Register of Historic Places in 1975.

While the original system of streets and many notable early buildings in the commercial center remain intact, the demolition or inappropriate alterations to historic buildings and incompatible new construction threaten to diminish the historic character of Sumter's downtown district. The residential neighborhoods, particularly Hampton Park, retain a greater level of integrity with houses dating from the late-nineteenth to the mid-twentieth century that reflect the architectural styles and tastes that were popular during the period. However, the Hampton Park Historic District continues to be challenged by the local economy, permissive land use policies, absentee ownership, property neglect, suburban sprawl, perception of low quality schools and high crime rates. The establishment of the overlay districts with design guidelines and the review process in 1996 has helped to address these threats through the stabilization and revitalization of Downtown and Hampton Park by preserving the unique historic character of these areas.

The historical overview was adapted from the 1996 Design Review Guidelines Manual.

PAGE LEFT INTENTIONALLY BLANK

2

UNDERSTANDING HISTORIC CHARACTER

A building's historic character derives from the physical features that comprise its appearance, as well as its relationship to its site and setting. Architectural styles and forms provide useful frameworks for understanding historic character. Form denotes the overall shape and massing of a building, while architectural style relates to the decorative ornament applied to a building form. In some cases, architectural styles are integral to the form of the building.

Architectural styles reflect certain periods of development, as well as the livelihoods and tastes of a building's inhabitants. Each style has its own distinctive features, expressed through materials, forms, and decorative details. Within the same style, there can be a range of appearances, resulting from factors such as owner preferences, site constraints, and building function. Vernacular interpretations of more ornate styles will feature simpler forms and detailing. Buildings often reflect influences from several styles and do not fit neatly into one category. The following section illustrates the most common residential and commercial architectural styles in Sumter's historic districts. The ability to recognize the repeating architectural styles and forms that connect a building to its neighborhood, and its place in the development of the city, enables building owners to make informed decisions regarding renovation, additions, and new construction.

PAGE LEFT INTENTIONALLY BLANK

2.1 RESIDENTIAL STYLES

QUEEN ANNE (1880-1910)

The Queen Anne style was the dominant domestic building style in the United States in the late nineteenth century. Eclectic and richly embellished, the style was popular during the reign of Victoria, the Queen of England, and is often misidentified as the “Victorian” style. Named and inspired by a group of British architects led by Richard Norman Shaw, early American examples featured half-timbering and patterned masonry, drawn from English late medieval vernacular building traditions. The uniquely American spindlework interpretation, characterized by delicate turned porch supports and lacy millwork, soon followed and became dominant. Pattern books and an expanded railroad network, which made a host of mass produced materials and details available across the nation, helped to popularize the style. The free classic interpretation, typified by features such as classical columns, dentils, and Palladian windows, became increasingly widespread as preferences shifted to classical styles in the early 1890s.

Plan: Generally balloon frame with asymmetrical massing and irregular plans, including projecting bays.

Roof: Complex gable and hipped roofs, often with dominant front gable or corner tower and decorative cresting or finials.

Chimney: Interior and exterior with decorative brick corbelling.

Entrance: Ornate milled designs with large glass lights, sidelights, and transoms.

Windows: One-over-one double-hung sash, use of stained or beveled glass, and feature windows.

Materials: Weatherboard siding, wood shingles in gables, eave vergeboard and milled panels.

Porches: Full width or wraparound with turned supports, balusters, and scroll sawn friezes or classical columns.

Details: Use of spindlework, milled panels, patterned shingles, half-timbering, eave vergeboard, and decorative brick.

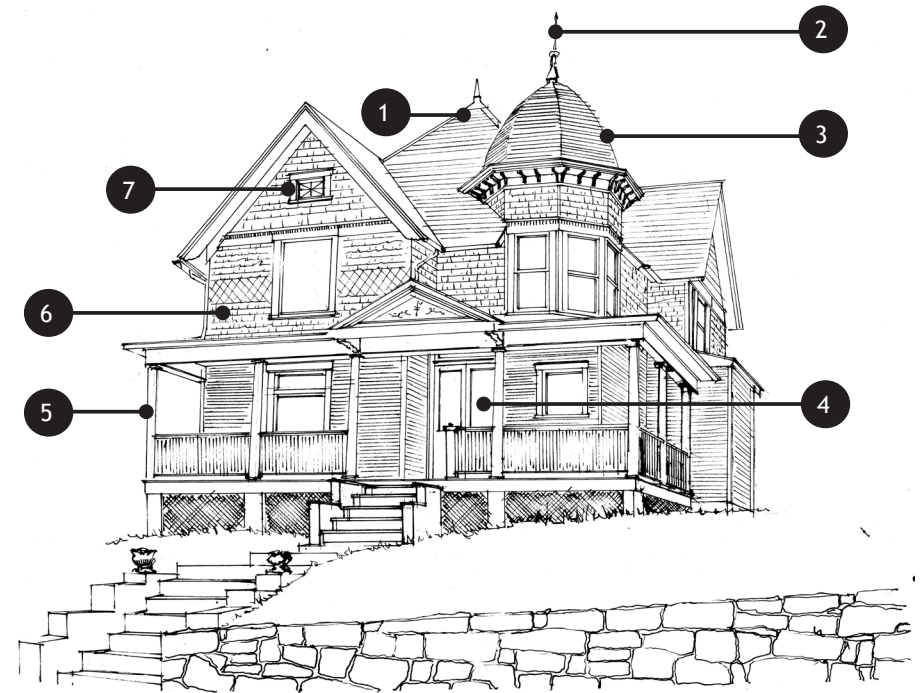

1. Steeply Pitched Roof of Irregular Shape
2. Finial
3. Corner Turret
4. Front Door with 3/4 Glazing
5. Partial or Full-Width Porch (can wrap around one or two sides)
6. Textured Shingles
7. Windows with Leaded Glass

FOLK VICTORIAN (1870-1910)

Inspired by the complex and ornamented Queen Anne style of the same period, the Folk Victorian style spread to small cities and towns with the expansion of the railroads across the United States. This economical form of transportation made mass produced, milled wood ornament available for application onto simple, vernacular house forms used by local builders. Owners of older folk houses sometimes applied the ornament in an effort to update their house according to trend. The use of decorative detailing was primarily confined to the porch and cornice line. In addition to the Queen Anne style, detailing was also derived from Italianate and Gothic Revival styles of the Victorian era.

Plan: Simple forms that may be rectangular, square, or L-plan.

Roof: Intersecting gable, front gable, side gable, or hipped.

Chimney: Interior and exterior with limited detailing.

Entrance: Single light glass and wood designs, sometimes with ornate panels and transoms.

Windows: One-over-one or two-over-two double-hung sash.

Materials: Weatherboard siding, wood shingles in gables, eave vergeboard, and milled panels.

Porches: Partial or full width with turned supports, balusters, and scroll sawn friezes.

Details: Use of spindlework, milled panels, patterned shingles, and eave vergeboard.



1. Brackets under Eaves
2. Spindlework Porch Detailing
3. Wide Lap Siding
4. Turned Column
5. Single Light Door
6. Novelty Wood Siding
7. Intersecting Gable Roof

COLONIAL REVIVAL (1880-1955)

The Colonial Revival style was the most popular style for domestic buildings in the first half of the twentieth century. The style emerged out of interest in the colonial past of America, first inspired by the Philadelphia Centennial of 1876. The popularity of the style intensified with the World's Columbian Exposition in 1893, which featured monumental classical buildings and replicas of famous colonial buildings. As the colonial revival movement represented a search for a national architectural identity, the resultant style encompasses a variety of colonial styles, including English Colonial, Spanish Colonial, and Dutch Colonial. The popularity of the style continued to grow with the Colonial Williamsburg restoration of the late 1920s. After World War II, a simplified and economical version of the style emerged, reflecting postwar building trends towards mass production and accelerated schedules.

Plan: Rectangular or square plan and symmetrical façade.

Roof: Side gable, hipped, or gambrel often with gable or shed dormers and slate sheathing.

Chimney: Interior and exterior with corbelled brick detailing.

Entrance: Paneled doors embellished with flanking pilasters, fanlight transoms, sidelights, and pediments.

Windows: Multi-pane, double-hung sash often with shutters.

Materials: Usually red brick with white trim and decorative quoining; weatherboard siding sheathes some examples.

Porches: Stoops or entrance porticos of various widths with classical columns.

Details: Dentiled or modillioned cornices, egg-and-dart moldings, and fretwork.

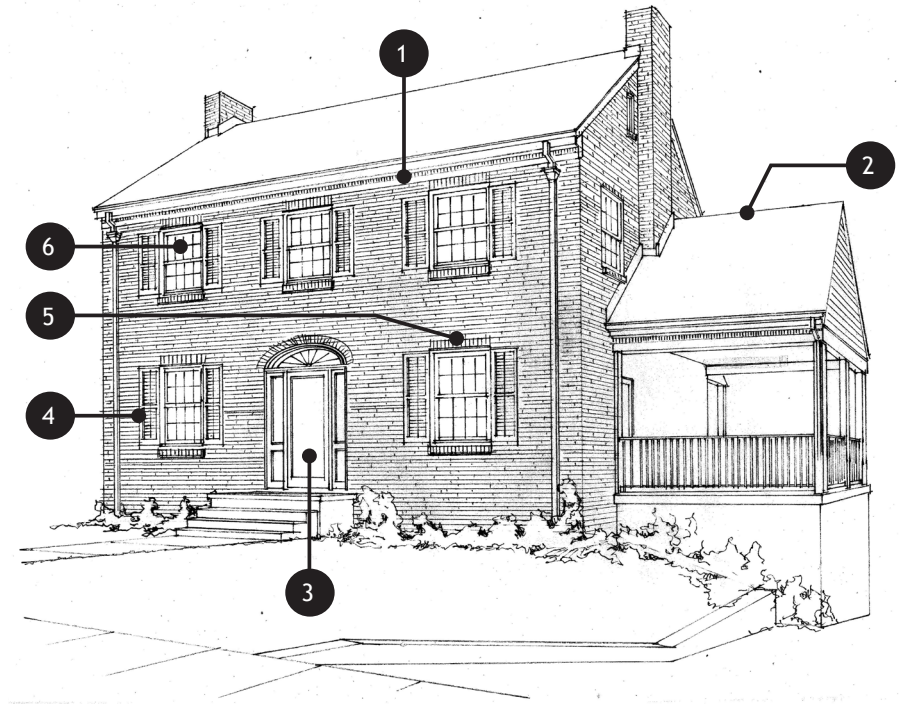

1. Dentils
2. One-story Side Wings (Open or Enclosed)
3. Accentuated Front Door with Fanlight
4. Shutters Common
5. Brick Soldier Course Above Windows
6. Double-Hung Windows with Multi-Pane Glazing

CRAFTSMAN (1905-1930)

The Craftsman style gained popularity in the early twentieth century as an American extension of the British Arts and Crafts Movement of the 1880s. A departure from the ornate styles of the Victorian era, the Craftsman style celebrated the use of natural materials, craftsmanship, and simplicity. The most familiar form associated with the style is the Craftsman Bungalow, made popular by California architects Greene and Greene after publishing their designs in national magazines. Craftsman bungalows were promoted to the middle class as modern houses that embodied an honest, simple lifestyle. Pattern books and mail-order catalogues offering affordable plans and materials spurred nationwide popularity of this dwelling type. The Craftsman style is also associated with the popular American Foursquare form, which offered another practical and affordable option for the middle class.

Plan: Rectangular or square, with horizontality emphasized.

Roof: Front or side gable (bungalow) and hipped or pyramidal (foursquare) often with overhanging eaves and large dormers.

Chimney: Both interior and exterior faced in brick, stone, or stucco.

Entrance: Multi-light glass and wood designs, sometimes with sidelights.

Windows: Double-hung sash with vertical divisions in upper sash, often paired or grouped.

Materials: Weatherboard, wood shingle, stucco, brick veneer, or random stone; often combining two of these materials.

Porches: Full or partial width with tapered columns on brick or stone piers and square balusters or solid brick or shingled knee walls.

Details: Exposed rafter ends, knee brace brackets, purlins, and wood shingles in gable ends.



1. Shed Dormer
2. Roof Rafters Usually Exposed
3. Wood Shingles in Gable Ends
4. Small Window Flanking Chimney
5. Paired Multi-light Over Single-Light Windows
6. Square Masonry Piers with Tapered Wood Posts

SPANISH COLONIAL REVIVAL (1890-1940)

The Spanish Colonial Revival style draws from Spanish and Spanish Colonial architectural traditions. The earliest revival of Spanish architecture in the United States was the Mission style, which began in California and drew inspiration from the Spanish Colonial architecture of the Southwest. After the Panama-California Exposition, held in San Diego in 1915, architects began to look directly to Spain for inspiration. The style later melded influences from other parts of the Mediterranean, including North Africa, Greece, France, and Italy. The exotic and eclectic style reached its height of popularity in the 1920s and early 1930s.

Plan: Asymmetrical massing.

Roof: Gable, hipped, or flat often with curvilinear parapets and red tiled roofs.

Chimney: Interior and exterior covered in stucco often with elaborate chimney tops.

Entrance: Emphasized with spiral columns, pilasters, carved stonework, or patterned tiles.

Windows: Focal windows that may be quatrefoil, triple-arched, or parabolic.

Materials: Stucco or plaster walls.

Porches: Prominent porches with round arches, balconies with wood or iron railings.

Details: Decorative vents, round arches, patterned tiles.



1. Red Tile Roof Covering
2. Stucco Wall Surface
3. Arched Window Openings
4. Balcony with Wood or Iron Railing

TUDOR REVIVAL (1890-1940)

The Tudor Revival style stems from English building traditions and became a popular residential style in American suburbs in the early twentieth century. The earliest examples in the United States were large, architect-designed landmarks built on the fringes of major cities. Use of the style conveyed a sense of pedigree and refinement due to its associations with the country houses of the British aristocracy. After World War I, a less formal and smaller version of the Tudor Revival style swept across the American suburbs, rivaling the Colonial Revival style in popularity.

Plan: Asymmetrical façade with one or more prominent front gables.

Roof: Steeply pitched gable roof often sheathed with slate.

Chimney: Large, prominent chimney on front or side of house, sometimes with decorative chimney pots.

Entrance: Arched doorways with tabs of cut stone in surround brickwork, heavy board-and-batten doors with small inset window and strap hinges.

Windows: Traditional double-hung sash or narrow casements with leaded diamond or rectangular panes, often arranged in groups.

Materials: Brick, stucco, stone, wood or a combination of these materials.

Details: Decorative half-timbering in combination with brick or stone cladding laid in a crude or rustic manner.



1. Steeply Pitched Roof
2. Facade Dominated by one or more Cross Gables
3. Prominent Chimney
4. Masonry Walls
5. Arched Doorway
6. Grouped Windows with Multi-Pane Glazing
7. Brick Soldier Course Above Openings

2.2 COMMERCIAL AND INSTITUTIONAL STYLES

MAIN STREET COMMERCIAL FORM (1875-1940)

The Main Street Commercial form is an umbrella term that relates to traditional urban facades along major commercial thoroughfares. Main Street Commercial buildings feature ground level storefronts with large display windows to showcase goods to consumers. Upper stories usually functioned as living space for the shop owner or as storage. The buildings are most often attached to adjacent buildings with a shared party wall. Main Street Commercial buildings followed contemporary architectural fashions, so stylistic ornament can vary depending on building use and tastes. Many late-nineteenth century commercial buildings reflect influences of the Italianate style, with heavy cornices supported by decorative brackets and arched, hooded windows. Commercial buildings of the 1940s and 1950s often featured Moderne or International style detailing.

Plan: Symmetrical façade and rectangular plan.

Roof: Typically a flat roof with parapet.

Entrance: Glazed doors with transoms.

Windows: Large storefront windows to display goods surmounted by transom; double-hung sash windows typical on upper floors.

Materials: Brick, wood, stucco, and cast metal.

Details: Decorative wood, brick or metal cornices, patterned or corbelled brickwork, and sign bands.

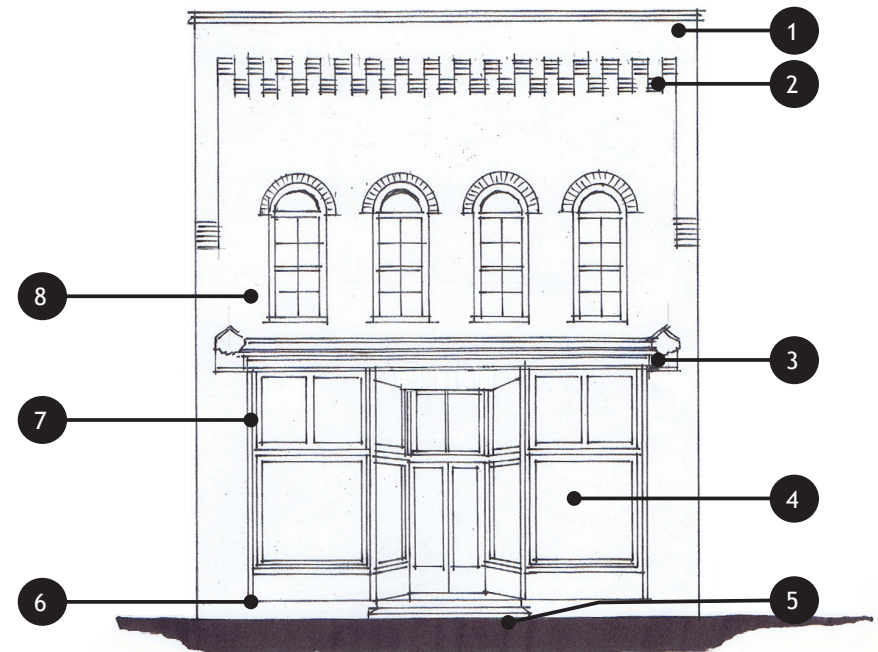

1. Flat Roof with Parapet
2. Corbelled Brick Cornice
3. Storefront Cornice
4. Large Display Windows
5. Recessed Entry
6. Bulkhead
7. Storefront Transom
8. Double-Hung Sash Windows

RICHARDSONIAN ROMANESQUE (1880-1900)

The Richardsonian Romanesque style was popular for impressive public buildings and churches. The style is the legacy of architect Henry Hobson Richardson, who pioneered his own version of the Romanesque style with Trinity Church in Boston. Heavy rough-faced masonry walls, arched entrances, and medieval towers are characteristic of the style. The use of structural stone masonry made this an expensive style, reserved for monumental buildings, such as the Sumter Opera House.

Plan: Asymmetrical massing often with towers.

Roof: Typically hipped with cross gables.

Entrance: Deep, arched entrances.

Windows: Round arches over windows, grouped rows of arched windows.

Materials: Rock-faced stone walls.

Details: Colonettes, arches on stout columns, contrasting stone colors and textures.

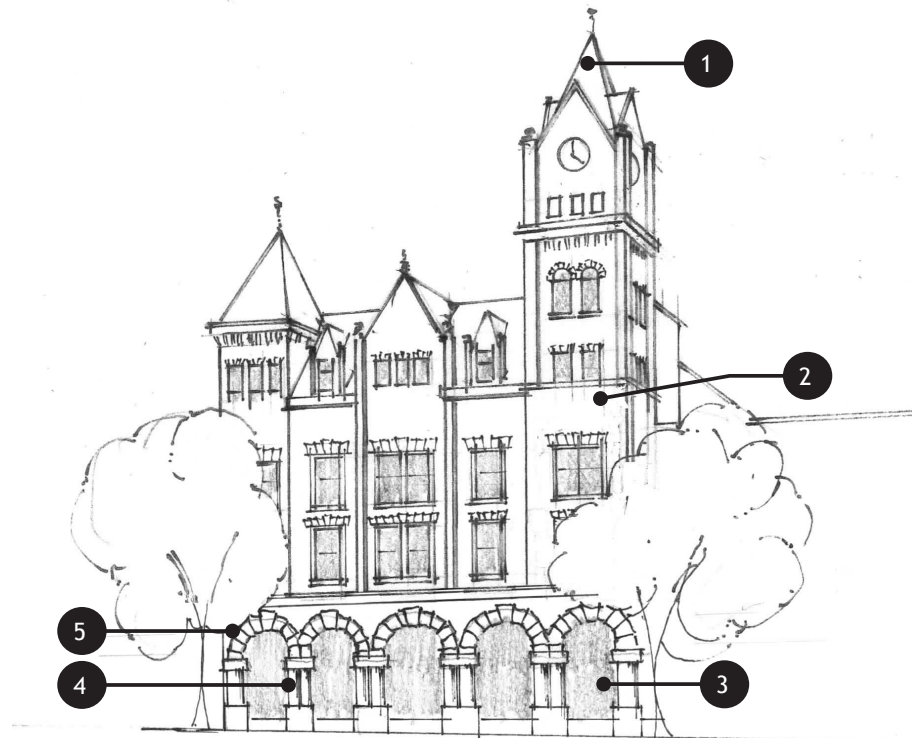

1. Tower
2. Rock-faced Stonewalls
3. Deep, arched Entrances
4. Arches on Stout Columns
5. Round Arches

NEOCLASSICAL REVIVAL (1890-1940)

The Neoclassical Revival style is a broad term that encompasses a range of classical architecture during the late nineteenth and early twentieth centuries. Inspiration for the style stems from the Beaux-Arts Classicism taught at the Ecole des Beaux-Arts in Paris, which emphasized the study of classical architecture. The Columbian Exposition in 1893, with its theme of monumental classical architecture, revived national interest in the classical mode and inspired numerous public and commercial buildings in the following decades. A more flexible version of its grander cousin, the Beaux-Arts style, the Neoclassical Revival style spread across the nation, often used for county courthouses, main street commercial buildings, and bank branches. Prominent examples in Sumter include the Sumter County Courthouse and the former Bank of Sumter.

Plan: Symmetrical façade and rectangular plan.

Roof: Flat or low hipped roofs sometimes with roofline balustrades.

Entrance: Doors with elaborate decorative surrounds and arched openings.

Windows: Double-hung sash windows, sometimes arched and pedimented.

Materials: Masonry (smooth, light colored stone or brick).

Details: Monumental columns, pilasters, quoins, decorative garlands, floral patterns.

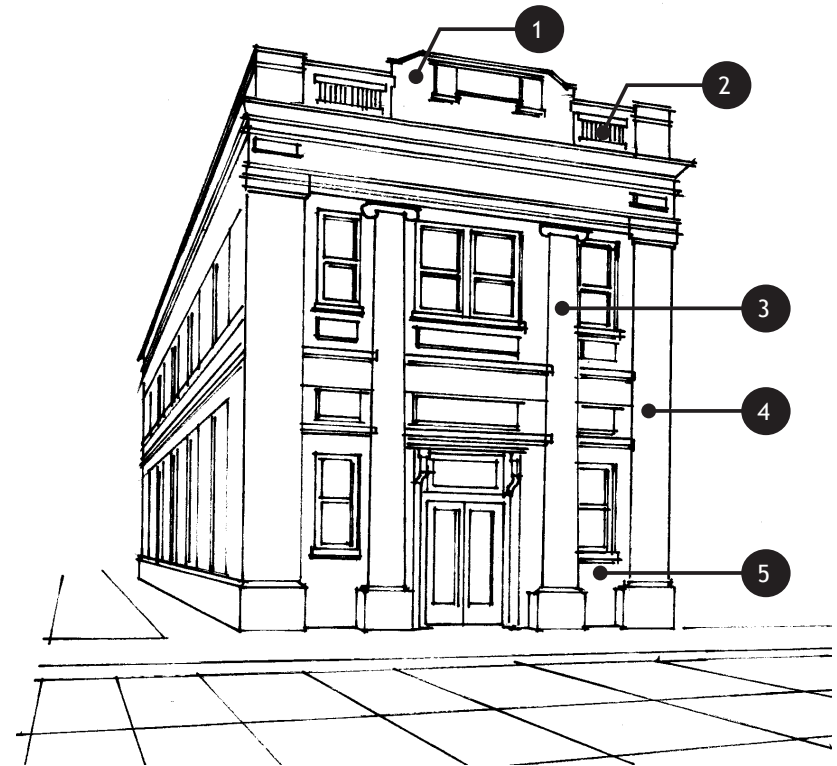

1. Flat Roof
2. Roofline Balustrade
3. Monumental Columns
4. Pilasters
5. Smooth Masonry Walls

PAGE LEFT INTENTIONALLY BLANK

3

PLANNING A PROJECT

A successful project requires careful consideration of a building's past history, present condition, and future use. These guidelines intend to assist property owners in developing an appropriate approach for the treatment of their historic building or a compatible design for new construction within the overlay districts. The recommended approach in these guidelines is based on the *Secretary of the Interior's Standards for Rehabilitation*. The basic premise of these *Standards* is to identify the "character-defining" architectural elements, features, and historic fabric of a building that convey its historic or architectural significance. Once identified and their condition assessed, these components of the building should be retained and repaired, if necessary, in order to retain the building's historic character. Where building components are either missing or deteriorated beyond repair, the recommended approach is to replace in kind to match the historic component based on either physical evidence or graphic documentation, which may include historic photographs or drawings, rather than conjecture that would give a false sense of history. Alterations to the building over time may also become significant as part of its historic evolution. In planning for new construction—whether an addition to an existing historic building or the design of a new building—it is important that the new construction be compatible with the historic building or surrounding district as well as contemporary in its design to reflect its own history.

PAGE LEFT INTENTIONALLY BLANK

3.1 STEPS TO CONSIDER FOR A SUCCESSFUL PRESERVATION PROJECT

GAIN AN UNDERSTANDING OF THE BUILDING'S HISTORY

A project should begin with a thorough understanding of a building's history in order to appreciate its significance. Learning about a building's original and subsequent uses, owners, architectural style, dates of construction, and major alterations will help the owner understand the building's role in the district's history, as well as its design and current condition. Based on this understanding of its historic and architectural significance, the owner can identify the key components and materials that should be retained to preserve its historic character.

ASSESS CONDITIONS AND SELECT AN APPROPRIATE TREATMENT

Carefully assess the current condition of a building in order to develop an appropriate scope of work and treatment approach. Pay particular attention to the "character-defining" building components and materials identified as significant to determine the best treatment. The treatment that requires the least amount of intervention is preferred. Where significant historic building components and materials are intact, retain them. Where deterioration occurs, identify and correct the cause of the condition through sensitive repairs. Where such building components or materials are either missing or deteriorated beyond repair, replace them in kind to match the visual qualities of the historic based on physical evidence, original drawings, or historic photographs. If no such documentation or evidence exists, the replacement component or material should be simple in design so not to add a level of detailing that cannot be justified. Alterations should respect the historic character of a building and should not attempt to make it look older, newer, or more ornate. If a new feature or an addition is necessary, its design should be compatible with historic character of the building and have a minimal impact on historic features.

LOOK FOR COMPATIBLE USES

The best preservation approach is to provide for the continued use of a historic building. Uses similar to the original are ideal since they tend to have the lowest impact. Compatible uses also include those that require minimal alterations to the building and its site. Identifying an appropriate new use for a historic building requires a careful balance between retaining historic character while accommodating the programmatic requirements of the new use. A change in use will likely also require building upgrades to meet current code requirements for life safety, accessibility, and energy efficiency. Creative solutions, as well as some flexibility, will be needed to accommodate the requirements of a new use, but the effort is worthwhile as it gives a historic building a new life and preserves it for future generations.

The National Park Service publishes Preservation Briefs on various topics related to preserving, rehabilitating and restoring historic buildings. The publications help building owners recognize and resolve common issues prior to commencing work. These briefs, referenced throughout these guidelines, can be found online on the Technical Preservation Services page of the National Park Service website.

3.2 VISIBILITY AND LEVEL OF REVIEW

In addition to the identification of character-defining building components, it is important to understand the role that visibility plays in determining the application of the design guidelines. As the goal of the design review process is to preserve the visual qualities that give a district its historic character, the areas of a building that are highly visible from the public right-of-way are the most important. The highest level of preservation with the least amount of change is the best approach for these areas. In the Downtown Historic District, where adjacent buildings form solid “street walls,” this highly sensitive area may be limited to the front of the building. In the cases of corner buildings or freestanding buildings, such as larger institutional buildings or residences, this area may extend to the sides and rear of a building as well. Areas along the sides and rear of a building, depending on their location and surrounding buildings, may not be as highly visible as the front and are, therefore, secondary in their importance. These less visible, secondary areas allow for greater flexibility in their treatment. The level of sensitivity will also depend on the building’s overall significance, architectural style, and level of detailing.

3.3 INCENTIVES

Owners of contributing properties within the National Register-listed Sumter Historic District may be eligible to participate in the state and federal historic rehabilitation tax credit programs. The federal tax credit is equal to 20 percent of qualified rehabilitation expenditures and is limited to income-producing properties. The state historic tax credit is equal to 25 percent of qualified rehabilitation expenditures for owner-occupied residential uses and for income-producing properties if the credit amount does not exceed one million dollars. For income-producing properties with a credit amount of over one million dollars, the tax credit is equal to 10 percent. The South Carolina State Historic Preservation Office and the National Park Service administer these programs.

In order to be eligible for the programs, a property must be either individually listed on the National Register of Historic Places or contribute to a historic district listed on the National Register. Projects must meet a “substantial rehabilitation” test to qualify for each of the programs. All work on both the interior and exterior of the property must meet the *Secretary of the Interior’s Standards for Rehabilitation* and be reviewed and approved by the State Historic Preservation Office and the National Park Service for compliance.

The *Secretary of the Interior's Standards for Rehabilitation* are used by the National Park Service to determine if the rehabilitation of a historic building has been undertaken in a manner that is sensitive to its historic integrity. The *Standards* are broad, as they apply to historic rehabilitations across the United States. The recommendations found in these guidelines are based on the following standards:

1. A property shall be used for its historic purpose or be placed in a new use that requires minimal change to the defining characteristics of the building and its environment.
2. The historic character of a property shall be retained and preserved. The removal of historic materials or alteration of features and spaces that characterize a property should be avoided.
3. Each property shall be recognized as a physical record of its time, place, and use. Changes that create a false sense of historical development, such as adding conjectural features or architectural elements from other buildings, shall not be undertaken.
4. Most properties change over time; those changes that have acquired historic significance in their own right shall be retained and preserved.
5. Distinctive features, finishes, and construction techniques or examples of craftsmanship that characterize a property shall be preserved.
6. Deteriorated historic features shall be repaired rather than replaced. Where the severity of deterioration requires replacement of a distinctive feature, the new feature shall match the old in design, color, texture, and other visual qualities and, where possible, materials. Replacement of missing features shall be substantiated by documentary, physical, or pictorial evidence.
7. Chemical or physical treatments, such as sandblasting, that cause damage to historic materials shall not be used. The surface cleaning of structures, if appropriate, shall be undertaken using the gentlest means possible.
8. Significant archaeological resources affected by a project shall be protected and preserved. If such resources must be disturbed, mitigation measures shall be undertaken.
9. New additions, exterior alterations, or related new construction shall not destroy historic materials that characterize the property. The new work shall be differentiated from the old and shall be compatible with the massing, size, scale, and architectural features to protect the historic integrity of the property and its environment.
10. New additions and adjacent or related new construction shall be undertaken in such a manner that if removed in the future, the essential form and integrity of the historic property and its environment would be unimpaired.

PAGE LEFT INTENTIONALLY BLANK

4

GUIDELINES FOR REHABILITATION

Chapter 4 provides guidelines for the treatment of historic buildings in the Downtown Historic District and the Hampton Park Design Review District. The focus is on the rehabilitation and maintenance of those character-defining features that reflect the architectural style of a building and that relate a building to the district as a whole. The guidelines translate the general principles of historic preservation outlined in the previous chapter to the treatment of individual elements and components of residential and commercial buildings in the historic districts.

PAGE LEFT INTENTIONALLY BLANK

4.1 ROOFS

Roofs are significant character-defining features for most buildings. Therefore, the preservation of their original forms, materials, and elements is important. In Hampton Park, most roofs are gable, hipped, or a composite of both forms. These residential roofs can feature chimneys, dormers and decorative elements, including finials and cresting. Original roofing materials found in the neighborhood, such as standing-seam metal, slate and tile, also impart historic character. Most roofs in the Downtown Historic District are flat and concealed from view by a parapet. In most cases, changes to these roofs will not affect the overall integrity of the building.

A. PRESERVE ORIGINAL ROOF FORM AND PITCH.

- > Do not raise residential roofs to add additional stories.
- > Place new dormers and skylights inconspicuously on rear and secondary elevations not visible from the public right of way. Flush or flat skylights are more appropriate than raised or bubbled.

B. PRESERVE ORIGINAL ROOF MATERIALS.

- > Retain original roof materials, such as standing-seam metal, slate, or clay tile whenever possible.
- > Repair deteriorated sections of roofs with in-kind materials to match the original.

C. RETAIN ORIGINAL ROOF ELEMENTS AND ORNAMENTATION.

- > Preserve chimneys, dormers, exposed rafter tails, finials, and cresting.
- > Repair brick chimneys with brick and mortar to match the original.
- > Do not remove chimneys above the roofline, especially those on prominent elevations.
- > Stucco or paint a chimney only when its appearance detracts from the residence.

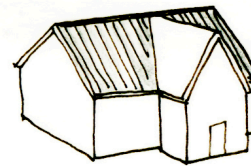

Intersecting Gable



Side Gable

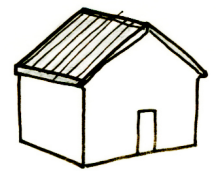

Front Gable

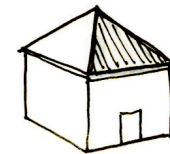

Pyramidal

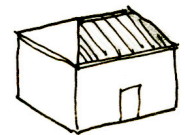

Hipped

D. REPLACE ORIGINAL ROOF MATERIALS WITH COMPATIBLE NEW MATERIALS.

- > Replace historic roofing materials only when damaged or deteriorated beyond reasonable repair.
- > Replace original roof materials in-kind with traditional materials whenever feasible.
- > Use substitute materials that convey the same visual appearance of the original roof when replacement with the traditional roofing material is not feasible.
- > Use substitute materials that resemble the original in size, shape, color, texture, pattern, and where possible, material composition.
- > Avoid materials that do not convey the same visual qualities as the original roof.
- > Reinstall roof ornamentation, such as finials, cresting and ridge caps.

MORE INFORMATION

Preservation Brief #4

Roofing for Historic Buildings

Preservation Brief #29

The Repair, Replacement and Maintenance of Historic Slate Roofs

Preservation Brief #30

The Preservation and Repair of Clay Tile Roofs

DEFINITIONS

Cresting: A decorative roof ridge, usually constructed of ornamental metal.

Dormer: A roofed projection from a sloping roof, often containing a window.

Eave: The projecting overhang of a roof.

Finial: An ornament that terminates the point of a gable or spire.

Soffit: The underside of a roof overhang.

Rafter Tails: The exposed ends of rafters that are visible along the eave.



Reinstalled finial after roof replacement.

4.2 FOUNDATIONS

Foundations are structural elements above or below grade that support a building. Masonry buildings often show no delineation between the foundation and wall plane, while brick foundations tend to contrast with the wall surface of frame construction. Most residences in Hampton Park stand on raised brick foundations that are either continuous walls or piers. The foundation walls of commercial buildings in the Downtown Historic District are usually below grade and are not visible.

A. MAINTAIN THE VISUAL AND STRUCTURAL QUALITIES OF HISTORIC FOUNDATIONS.

- > Repair and replace deteriorated foundation materials matching the original materials as closely as possible.
- > Do not obscure foundation walls with stone veneers or wall cladding materials, such as siding.
- > Retain the open appearance of brick pier foundations. The use of framed wooden lattice panels is appropriate to screen out debris and animals.
- > Recess pierced brick lattice, when used between piers, four to six inches behind the piers. Use brick that matches the original brick as closely as possible.
- > The use of concrete between brick piers may be allowed if a smooth stucco surface is added. Recess the concrete four to six inches behind the piers and add framed wooden lattice panels in front as a screen.

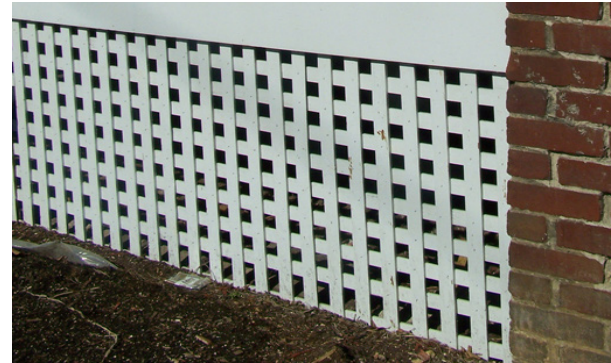

Overlap vertical and horizontal lattice strips at 90 degree angles for a traditional look.



Recessed pierced brick lattice retains the visual qualities of the brick pier foundation.

MORE INFORMATION

Preservation Brief #39

Holding the Line: Controlling Unwanted Moisture in Historic Buildings

4.3 EXTERIOR WALLS: MASONRY

Exterior masonry walls exist in both the commercial and residential historic districts. Masonry materials include brick, stone, concrete, stucco, and terracotta. Brick is the most common masonry material used in Sumter and is used primarily for exterior walls, foundations, and chimneys. Some exterior masonry walls are solid brick, while others are brick veneer, consisting of a single brick course over a wood frame structural system. In both cases, the brick exterior wall surface, and their associated bond patterns and textures, define the appearance and character of the building. Masonry elements can also be used to create decorative details and textures, such as corbelled brick patterns and inlays or belt courses.

The color and texture of masonry is an important defining feature, as is the mortar that bonds the masonry units. Mortar for most historic buildings is composed of a mixture of lime and sand, which allows for expansion and contraction of the mortar joints in hot and cold weather. In most cases, the use of modern Portland cement is not appropriate for historic buildings, as it is stronger than traditional historic mortars and does not allow for joint expansion or contraction. It is common for houses and commercial buildings in the historic districts to feature flush or concave mortar joints.

A. PRESERVE ORIGINAL MASONRY AND ITS VISUAL QUALITIES.

- > Retain masonry features that are important in defining the overall character of the building.
- > Do not remove or obscure masonry elements.
- > Do not paint unpainted masonry. Exceptions to this include masonry walls that have a patchwork appearance from extensive replacement or rebuilding.

B. MAINTAIN HISTORIC MASONRY MATERIALS.

- > Prevent water damage to masonry by repairing leaking roofs, gutters, downspouts and flashing and by generally diverting water away from the building.
- > Clean masonry only when necessary to stop deterioration or to remove heavy soiling.
- > Use the least abrasive means possible to clean masonry. Steam cleaning or a low-pressure wash at a pressure below 500 to 600 psi is recommended. Use mild detergent where necessary. Conduct a test patch on a small, inconspicuous section of the building first.
- > Test detergents or chemicals on small inconspicuous sections of the building first.
- > Do not sandblast or use abrasive cleaning methods.

C. REPAIR AND REPLACE HISTORIC MASONRY WITH IN KIND MATERIALS.

- > Repair or replace a masonry feature using masonry units that respect the size, texture, color and patterns of the historic material, as well as the mortar joint size and tooling.
- > Repair and repoint only areas where mortar has deteriorated, leaving sound mortar intact.
- > Repair cracks and unsound mortar with new mortar that matches the original in composition and appearance, including color.
- > Rake new mortar joints to match the originals.



Sandblasting can irreversibly damage masonry.



New mortar does not match the historic mortar in color or tooling.

MORE INFORMATION

Preservation Brief #1

Assessing Cleaning and Water-Repellent Treatments for Historic Masonry Buildings

Preservation Brief #2

Repointing Mortar Joints in Historic Masonry Buildings

DEFINITIONS

Course: A layer of masonry units, such as brick or stone, running horizontally.

Corbelling: Projecting brickwork to support or meet a structure above.

Quoin: Accented stone or brick blocks used to accentuate a building's outer corners.

Veneer: Covering of brick applied to a timber frame.

Repoint: To remove old mortar and replace with new mortar.

BRICK BOND PATTERNS

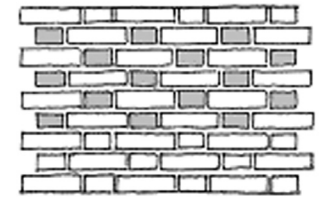

Flemish Bond

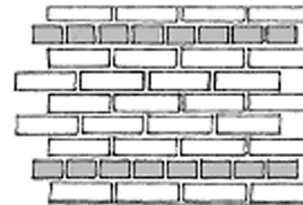

American Bond

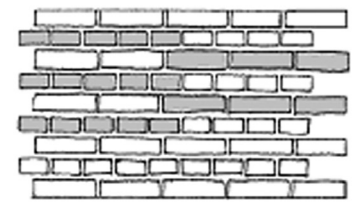

English Bond

4.4 EXTERIOR WALLS: SIDING

Many houses in Hampton Park are clad in wood siding. Horizontal lap siding, such as weatherboard or clapboard, is most common. Most exterior walls are sided from the frieze board just beneath the roof to the sill board at the foundation. Wood shingles are also found in the residential historic district, most commonly on Queen Anne and Craftsman style houses. These shingles are generally of square, elliptical, hexagonal or saw tooth designs. This exterior cladding usually adorns gables, dormers, or the second story of a house. Houses also feature other wood elements, including frieze boards, sill boards, corner boards, window and door trim, soffits, eaves, and decorative moldings.

A. PRESERVE AND MAINTAIN ORIGINAL WOOD SIDING AND OTHER WOOD FEATURES.

- > Retain original wood siding and other wood features, such as decorative shingles, cornices and frieze boards, soffits, eaves, trim and moldings.
- > Protect wood elements from water damage by repairing leaking roofs, gutters, downspouts and flashing.
- > Keep wood surfaces primed and painted.

B. REPAIR ORIGINAL WOOD SIDING AND WOOD FEATURES, WHERE FEASIBLE.

- > Restore deteriorated or missing sections rather than replacing or covering the entire feature.
- > Consider an epoxy consoildant to patch missing or deteriorated elements.
- > Splice in new materials of the material, design, color, texture and other visual qualities, while retaining as much of the original material as possible.

C. REPLACE ORIGINAL WOOD SIDING AND WOOD FEATURES IN-KIND.

- > Replace original wood siding and wood features only if beyond reasonable repair.
- > Match the original material in design, color, texture and other visual qualities and, where possible, material.

D. PRESERVE THE VISIBILITY OF EXTERIOR WOOD SIDING AND WOOD FEATURES.

- > Consider removing non-historic materials that conceal original wood siding and features and repair the underlying materials.
- > Do not cover wood siding with aluminum, steel, vinyl, brick and stone veneers, and other artificial materials.
- > Do not cover soffits, eaves and porch ceilings with aluminum, steel or vinyl siding.

MORE INFORMATION

Preservation Brief #8

Aluminum and Vinyl Siding on Historic Buildings

DEFINITIONS

Clapboard: Long boards lapping eachother horiztonally on a wood frame building that taper from bottom to top.

Corner Boards: A vertical board used as trim on the external corner of a wood frame house.

Frieze Board: A horizontal band located below the cornice.

SUBSTITUTE SIDING MATERIALS

City Council approved a general certification of appropriateness for vinyl siding in Hampton Park, which was adopted by Ordinance. As per the Ordinance, aluminum or vinyl siding for historic residential or commercial buildings can be administratively approved by planning staff under the following conditions:

- > The existing siding is so deteriorated that it cannot be repaired;
- > The substitute material can be installed without irreversibly damaging or obscuring the architectural features and trim of the building; and
- > The substitute material can match the historic material in size, profile, and finish so that there is no change in the character of the historic building.
- > In cases where a non-historic artificial siding has been applied to a building, the removal of such a siding, and the application of aluminum or vinyl siding would be an acceptable alternative, as long as the above mentioned first two conditions are met.

Although the Ordinance allows the use of aluminum or vinyl siding, these materials are not recommended in the historic districts, as they often do not match the dimensions and profiles of wood siding and conceal architectural details, such as decorative wood shingles and window cornices. The thickness of the added siding can also reduce the depth between the exterior walls and trim around windows and doors, contributing to a flat appearance. Furthermore, these materials are inflexible and cannot duplicate curves and contours of projecting bays and bay windows. Instead, they impose rigid angles that detract from the original appearance of a building. Covering original wood siding with a substitute material can result in future maintenance issues if underlying problems of rot and decay are not addressed or if the new material is installed without proper vapor barriers or ventilation, trapping moisture between the old and new siding. Although marketed as maintenance free and less expensive than traditional materials, these substitute materials dent, fade, crack, and warp over time. Use of these products may not be cost effective, as these issues are difficult to repair and may require wholesale replacement. The following actions are recommended if installing aluminum or vinyl siding over original wood siding:

- > Address underlying issues that may become more serious once the original material is concealed.
- > Install proper vapor barriers and ventilation to prevent excessive moisture between the original wall and the new material.



Wood siding provides texture and allows for contours that cannot be replicated with synthetic sidings.

4.5 ARCHITECTURAL DETAIL AND ORNAMENTATION

Architectural ornamentation helps to convey the historic significance and style of both commercial and residential properties. Commercial buildings often feature elaborate cornices at their rooflines of metal, wood, or corbelled brick. Milled wood decorative elements such as brackets, spindles, and vergeboard often embellished late-nineteenth century homes. Colonial Revival designs feature modillion blocks and dentils, while Craftsman houses are characterized by exposed rafters and knee braces. These decorative elements are essential to the architectural character of a building.

A. PRESERVE AND MAINTAIN ARCHITECTURAL ORNAMENTATION.

- > Retain architectural ornamentation, including but not limited to cornices, eave brackets, spindles, vergeboard, frieze boards, knee braces, and exposed rafter tails.
- > Do not remove or obscure architectural ornamentation.

B. REPLACE ORNAMENTATION WITH DESIGNS AND MATERIALS TO MATCH THE ORIGINAL.

- > Replace architectural ornamentation only when damaged or deteriorated beyond reasonable repair.
- > Match the profile, dimensions and materials of the original feature as closely as possible.

C. RESTORE MISSING ORNAMENTATION BASED ON PHOTOGRAPHIC OR PHYSICAL EVIDENCE.

- > Do not apply ornamentation that has no historical basis, as it would create an appearance not in accordance with the building's original design or style.
- > Consider simple cornice of wood or metal on commercial buildings that have lost their cornice. Materials such as fiberglass reinforced concrete may also be appropriate.



MORE INFORMATION

DEFINITIONS

Bracket: A small structural support located under eaves, balconies, or other overhangs. Frequently used for ornamentation rather than structural support.

Cornice: Decorated trim work where the roof meets the wall.

Dentils: Small closely spaced blocks projecting from a cornice.

Gingerbread: Decorative elements of intricately turned or sawn wood applied to the exterior trim; especially popular during the Victorian era.

Knee brace: A diagonal brace set in the corner of a rectangular frame, typically found on Craftsman style houses.

Modillions: Small bracket-shaped ornaments under a cornice.

Vergeboard: A decorative board along the rake of a gable that conceals the rafters.

Windows, and the architectural details surrounding windows, reflect the architectural style and date of a building and are important aspects of architectural character. Basic window functions include allowing light into the interior, providing fresh air and ventilation, serving as a visual link to outside, and enhancing the appearance of a building. The location, size and style of windows can also suggest the interior plan or function of spaces. Historic wood windows can last for over one hundred years with periodic maintenance to prevent deterioration and maintain thermal efficiency. The addition of a storm window can provide thermal efficiency equal to a replacement window with insulated glass.

A. PRESERVE AND REPAIR HISTORIC WINDOWS.

- > Retain historic windows that contribute to the historic character of a building, including functional and decorative features, such as frames, sash, muntins, mullions, decorative glass, sills, trim, surrounds, and shutters.
- > Repair original windows by patching, splicing, consolidating, weather stripping, caulking, and replacing missing glass.
- > Replace only those features that are beyond repair, rather than replacing the entire window unit. For example, sash replacement maybe be a less costly alternative to a full window replacement. Match the original feature in design, dimension, and material.
- > Improve thermal efficiency by securely locking windows, adding weather stripping, and installing interior or exterior storm windows.
- > Preserve original window locations, sizes, and types and restore altered window openings to their historic configurations.

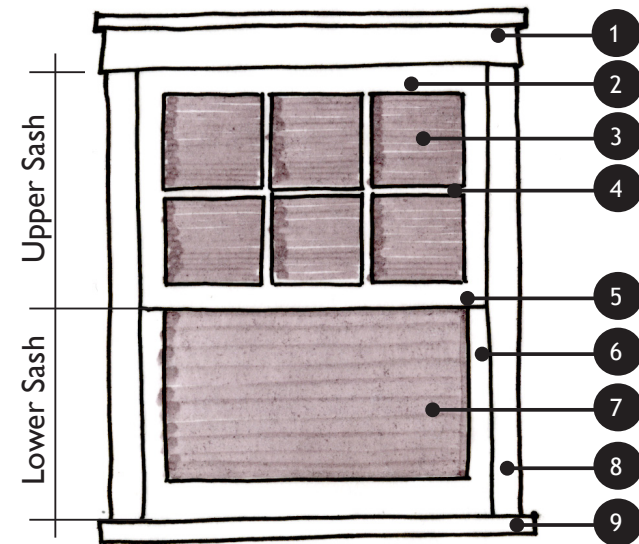

1. Head /Cap
2. Top Rail
3. Window Light (6 Panes)
4. Muntin
5. Meeting Rail
6. Stile
7. Window Light (1 pane)
8. Casing
9. Sill

REPLACEMENT WINDOWS

City Council approved a general certification of appropriateness for vinyl replacement windows in Hampton Park, which was adopted by Ordinance. As per the Ordinance, vinyl replacement windows can be administratively approved by planning staff. To obtain administrative approval, the new windows must have the same muntin and pane configuration as the historic windows.

ENERGY EFFICIENCY

Contrary to popular belief, replacing windows alone will not result in major energy savings. Air loss attributable to windows in most buildings is only about 10 percent, according to the U.S. Department of Energy. Furthermore, studies have shown that window replacement is often not cost effective since new insulated windows do not pay for themselves in energy savings in a reasonable length of time. Historic wood windows also have a much longer performance life than replacement windows, which cannot be easily repaired or recycled. In fact, some replacement windows must be replaced completely if a single part fails. There are ways to improve the performance of historic windows that do not require replacement, such as weather stripping, caulking, and storm windows.

WINDOW TYPES



Double-Hung Sash with Decorative Lintel



Feature Window



Grouped or Composite Windows



Steel Casement Windows



Palladian Window



Fixed Art Glass Window

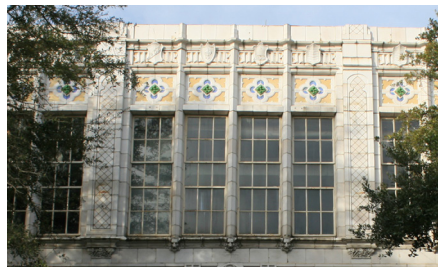

Composite Window



Paired Windows with Transoms



Double-hung Sash Wood Windows

B. REPLACE HISTORIC WINDOWS WITH COMPATIBLE NEW WINDOWS.

- > Replace historic windows only when damaged or deteriorated beyond reasonable repair or missing.
- > Match the original windows in design, dimension, muntin profile, pane configuration, finish and, where possible, material. If the all original windows are missing, replacement windows should reflect a design appropriate for the building form and architectural style.
- > Avoid the use of false muntins, either internal or applied exterior grilles, which do not resemble the profile and depth of historic muntins.
- > Avoid reducing or increasing the size of a historic opening to accommodate a smaller or larger window. Where necessary, limit this treatment to the rear or side elevations not visible from the street.
- > Use clear glass on the primary elevation and secondary elevations visible from the street. Tinted glass may only be installed on rear or secondary elevations not visible from the street.
- > Avoid elaborate stained glass or other decorative glass on primary or visible secondary elevations unless there is evidence that these features existed historically.

C. MAINTAIN THE PATTERN AND RHYTHM OF ORIGINAL WINDOW OPENINGS.

- > Select an inconspicuous location for new window openings, such as the rear or side elevations not visible from the street.
- > Add new window openings in a manner that minimizes impact on historic features and subtly distinguishes them from historic windows.

- > Match the general size and alignment of original window openings when adding a new window opening.
- > Do not enclose or obscure original window openings with added materials.

D. DESIGN STORM WINDOWS TO MINIMIZE VISUAL IMPACT.

- > Install interior or exterior storm windows that match the original window opening in size and dimension, with the meeting rail location matching that of the original window.
- > Position storm windows within the window opening rather than attaching it to the frame.
- > Use wood or anodized aluminum storm windows when possible. Raw or untreated aluminum frames may be acceptable if the aluminum is primed and painted to match the window trim.

MORE INFORMATION

Preservation Brief #9

The Repair of Historic Wooden Windows

DEFINITIONS

Fenestration: The arrangement of the openings of a building.

Sash: The wood frame of a window in which the glass panes are set.

Mullion: A vertical member separating and supporting windows and doors.

Muntin: Small bars separating and holding panes of glass within a window sash.

Glazing: Another term for glass that is used in a window.

4.7 SHUTTERS

Exterior shutters historically provided a means for ventilation and light control. They could also be closed to protect a building from the elements or for additional privacy. The functionality of shutters diminished with the advent of air conditioning in the twentieth century and now they primarily act as ornamental features. Shutters can be paneled, louvered, or feature cut out designs. Some buildings, including most downtown commercial buildings, were never intended to have shutters. The architectural style and date of a building can help determine if shutters are appropriate.

A. RETAIN AND REPAIR ORIGINAL SHUTTERS AND THEIR HARDWARE.

B. REPLACE HISTORIC SHUTTERS WITH A COMPATIBLE DESIGN IF REPAIR IS NOT A FEASIBLE OPTION OR IF ORIGINAL SHUTTERS ARE MISSING.

- > Match replacement shutters to the materials, proportions, and style of the original shutters.
- > Use shutters of wood or a wood composite rather than metal or vinyl.
- > Size new shutters to cover the window opening when closed.
- > Mount shutters on hinges to give the appearance of being operable.
- > Base replacement of missing shutters on historic and pictorial evidence.
- > Add shutters only when in keeping with the architectural style of the house.



Shutters fit the window opening and are in keeping with the architectural style.



Height of shutter should match height of window opening or sash frame. Shutter width should equal half the width of the window opening.

4.8 DOORS

Doors provide attractive, welcoming entrances to interior spaces. Like windows, they reflect the architectural style of a building and are important elements of architectural character. Residential doors are characterized by wood panels and in some cases, glass panes. The arrangement of panels and panes will differ depending on the style of the door. Main entrances tend to feature decorative elements, such as sidelights, transoms, fanlights, and milled surrounds. It is common for commercial doors to have more glazing, often with a single glass pane and sometimes raised wood panels. A more detailed discussion of commercial doors can be found in the section on storefronts.

A. PRESERVE AND REPAIR HISTORIC DOORS THAT CONTRIBUTE TO THE CHARACTER OF A BUILDING.

- > Retain and repair historic doors, including decorative features such as trim, sidelights, transoms, fanlights, and surrounds. Where possible, retain original hardware.
- > Preserve original door locations, sizes, and types and restore altered door openings to their historic configurations.
- > Avoid painting previously unpainted doors unless extremely weathered.

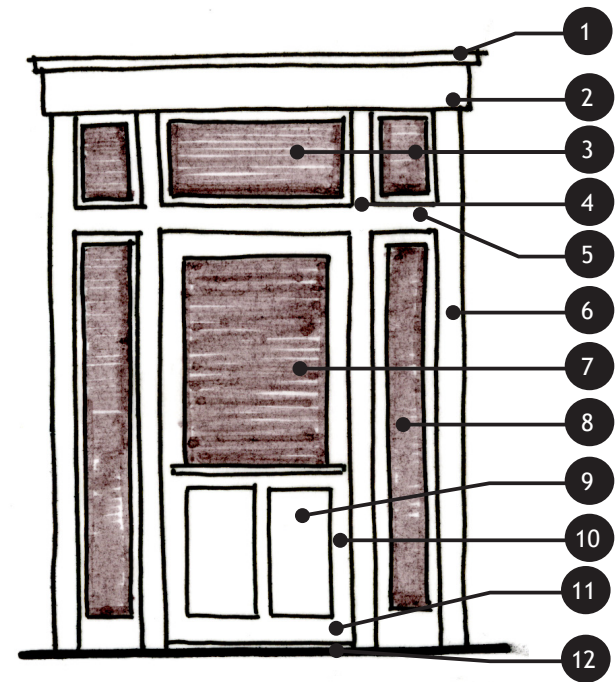

- | | |
|---------------------|--------------------|
| 1. Cornice Moulding | 7. Door Glazing |
| 2. Head/Cap | 8. Side Light |
| 3. Glass Transom | 9. Panel |
| 4. Mullion | 10. Stile |
| 5. Transom Bar | 11. Rail |
| 6. Frame/Casing | 12. Sill/Threshold |



Colonial Revival Style Doors

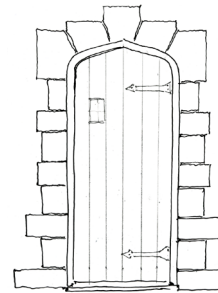

Tudor Revival Style Door

A variety of door styles are found in the historic districts. A traditional design that is compatible with your building is recommended. See Chapter 2 to determine the architectural style of your building.



Queen Anne and Folk Victorian Style Doors

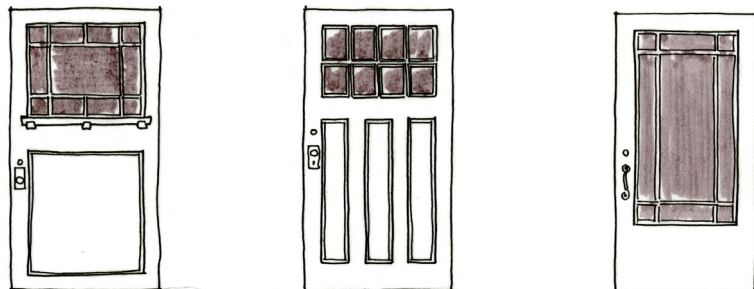

Craftsman Style Doors

MORE INFORMATION

DEFINITIONS

Sidelights: Stationary glass panes flanking an entrance door.

Transom: Window above the front door.

Rail: Horizontal framing member between door panels.

Stile: Vertical framing member of a paneled door.

Beveled Glass: Rectangular glazing with an angled surface cut around its entire periphery.

B. REPLACE A HISTORIC DOOR WITH A COMPATIBLE DESIGN IF REPAIR IS NOT A FEASIBLE OPTION OR IF MISSING.

- > Consider first a salvaged door of the appropriate style or a suitable original door from a rear or secondary elevation when an original door on the primary façade requires replacement.
- > Install a replacement door that resembles the original door in design, dimension, and material. If the original door is missing, the replacement door should reflect a design appropriate for the building form and architectural style.
- > Avoid altering original door openings by blocking them in, or expanding or reducing their size. Where necessary, limit this treatment to the rear or side elevations that are not visible from the street.

C. ADD NEW DOOR OPENINGS IN A MANNER THAT MINIMIZES IMPACT ON HISTORIC FEATURES AND SUBTLY DISTINGUISHES THEM FROM HISTORIC DOORS.

- > Select an inconspicuous location for new door openings, such as the rear or side elevations not visible from the street.
- > Use clear glass for doors on the primary and readily visible secondary facades. Tinted glass may only be used on rear or side elevations not visible from the street.
- > Decorative or stained glass is only appropriate if there is evidence that this feature existed historically.
- > Modern wood, fiberglass, or steel doors may be appropriate on rear or side elevations that are not visible from the street.

D. DESIGN STORM DOORS AND SCREEN DOORS TO MINIMIZE VISUAL IMPACT.

- > Retain original screen doors and storm doors that complement the character of a house.
- > Use the same overall dimensions as the main door for a new screen door or storm door.
- > Minimize rail and stile framing as much as possible to allow for maximum visibility of the main door.
- > Relate the rail and stile arrangement closely to that of the main door.
- > Avoid security doors with extensive metal grillwork or bars on primary entrances and secondary entrances visible from the street.
- > Construct new screen doors and storm doors of wood, composite, or aluminum.
- > Paint screen and storm doors the same color as the main door.



This full-light storm door allows for visibility of the historic door.

4.9 PORCHES

Porches are often the focal points of historic homes, especially when positioned on primary elevations. They provide an area for people to gather and socialize, as well as serving as an important transition space between the interior and exterior of a residence. Porches can define the overall character and style of a building, with their distinctive columns, railings, steps, and decorative detailing. In Hampton Park, almost all houses have some type of porch on the primary or street elevation. Side and rear porches are less common, but examples do exist in the district. Some porches extend across the entire width of the façade while others only shelter the entrance. Most are one story in height, with two-story porches being rare. While the overall plan and form of porches are similar, their detailing and ornamentation varies depending on the architectural style of the house.

A. RETAIN AND REPAIR ORIGINAL PORCH ELEMENTS AND MATERIALS.

- > Preserve and maintain original porch elements including floors, beadboard ceilings, columns and supports, pilasters, railings, steps, lattice, and decorative trim.
- > Remove inappropriate materials such as open-riser stairs, metal porch supports, decking used as porch flooring and inappropriately installed lattice panels.
- > Repair the deteriorated portions of an element, rather than replacing an entire feature.
- > Consider epoxy consolidants to rebuild deteriorated elements.

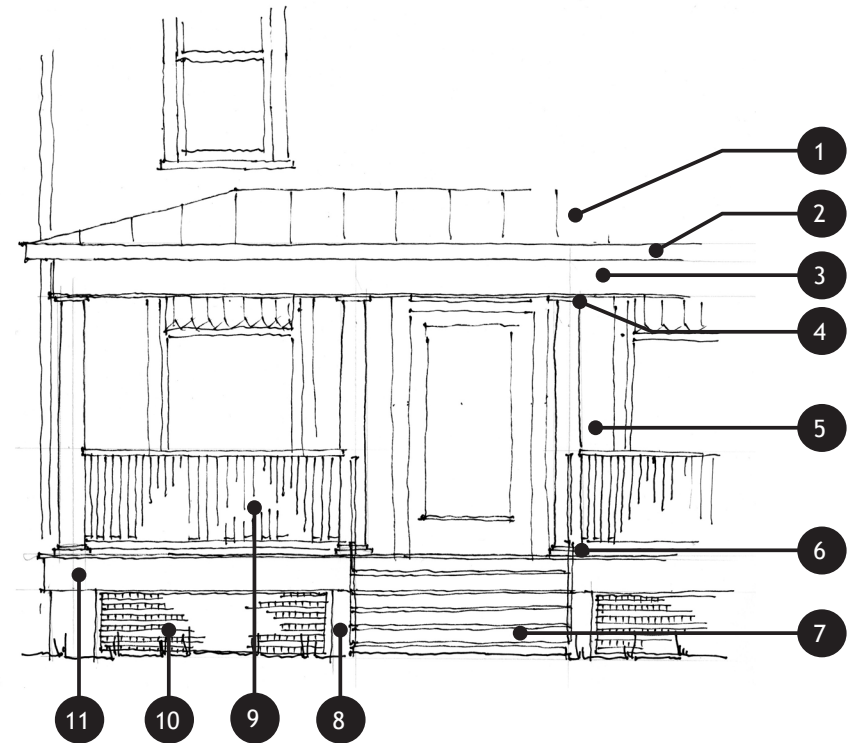

- | | |
|-------------------|------------------------|
| 1. Porch Roof | 7. Closed-riser Stairs |
| 2. Fascia | 8. Brick Pier |
| 3. Entablature | 9. Balusters |
| 4. Column Capital | 10. Wood Lattice |
| 5. Column Shaft | 11. Skirt Board |
| 6. Column Base | |

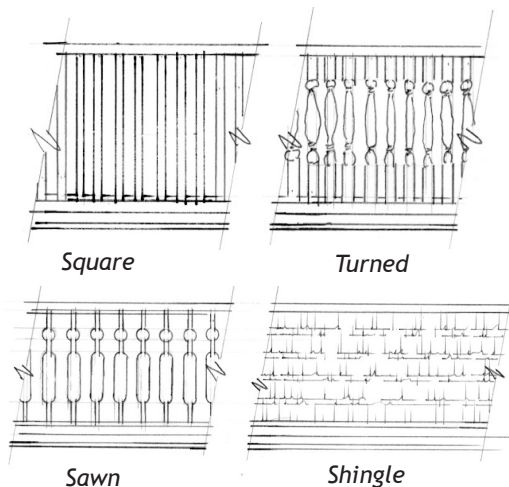
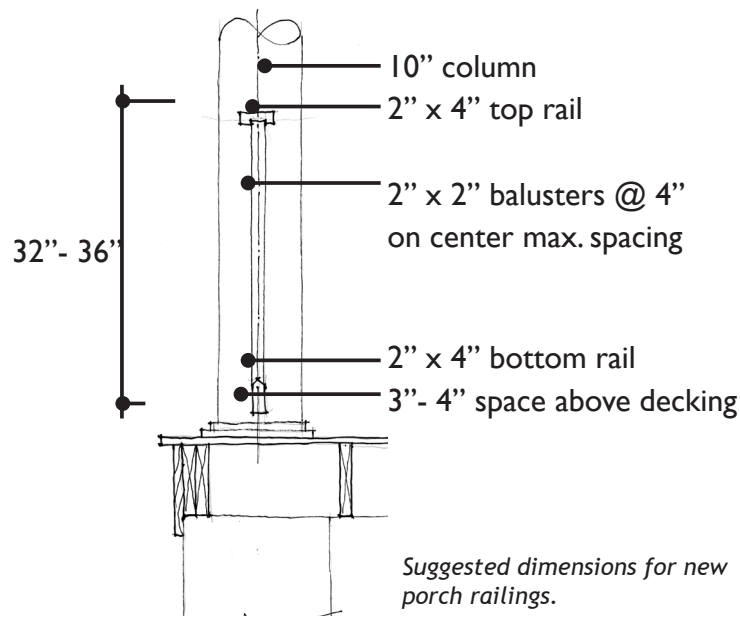

Examples of balusters.

B. REPLACE DETERIORATED OR MISSING PORCH ELEMENTS AND MATERIALS IN KIND.

- > Replace deteriorated or missing features with materials compatible with the original in size and shape, detail and dimension, color and texture.
- > Choose proper replacement columns or supports for the style of the house, based on existing evidence or historical information.
- > Replace deteriorated wood columns with new wood columns or composite columns that resemble wood. Metal or aluminum columns are not appropriate for elevations visible from the public right of way.
- > Replace missing porch railings and balusters with traditional designs with appropriate dimensions.
- > Replace deteriorated wood porch floors with traditional tongue and groove floors if possible. Composite tongue and groove flooring may be an appropriate alternative.
- > Replace deteriorated or missing porch stairs with closed riser stairs of materials matching the original. Use simple handrails made of wood in a simple design.

C. PRESERVE AND RETAIN THE ORIGINAL PORCH CONFIGURATION.

- > Retain the open quality of porches, especially those on the front or a prominent elevation.
- > Porch enclosures may be appropriate on the rear or side elevations that are less prominent.
- > Design porch enclosures in a manner that will not obscure, damage, or destroy character-defining features.
- > Use screen panels with the minimum number of vertical and horizontal framing members necessary to enclose a porch. Recess panels behind porch columns and railings. Wood frames are more appropriate than metal.
- > Use glass with the minimum number of vertical and horizontal framing elements to enclose porches on secondary or rear elevations. Recess glass behind porch columns and railings.

D. PRESERVE AND RETAIN ORIGINAL PORCH LOCATIONS.

- > Reconstruct missing porches based on photographic or physical evidence that supports the prior existence of a porch. Match the features of the original, or if no photographic evidence exists, design a new porch that is compatible with the scale, design, dimensions, and detail of the house.
- > Locate new porches and decks with no historical basis in an inconspicuous location on the rear or side elevations of a building that are not visible from the street.

MORE INFORMATION

Preservation Brief #45

Preserving Historic Wood Porches

DEFINITIONS

Baluster: One of the vertical members contained within a railing.

Column: A vertical support consisting of a base, shaft, and capital.

Pilaster: A half-column attached to a wall.

Capital: The uppermost part of a column or pilaster; often embellished with classical ornament.

Entablature: The beam member supported by the columns below and horizontally divided into three subsections: architrave, frieze, and cornice.

Portico: A small covered entrance to a building, consisting of a roof that is often topped with a pediment, and supported by columns.

4.10 STOREFRONTS

The storefront is the most visible and noticeable part of a commercial building. An original storefront reflects the architectural character and period of a building's construction. Storefronts are differentiated from the upper façade by large display windows that flank the main entrance. The large expanse of glass allows for the display of goods and merchandise. The display windows rest on low bulkheads typically constructed of masonry or wood. Storefronts with recessed entrances often incorporate decorative floor tiles leading from the sidewalk. Historic storefronts are character-defining features of a building's façade and should be preserved.

Commercial storefronts are often altered and remodeled to reflect current retail trends or the needs of new tenants. Sometimes, these changes have intrinsic architectural and historic value and should be retained, as they have become part of the history of the building. If the entire storefront has been insensitively altered or replaced with a modern storefront, consideration should be given to a new, compatible storefront. When designing a new storefront, historic photographs or physical evidence can provide clues for an appropriate reconstruction. If no evidence of the original storefront exists, the new design should incorporate traditional storefront elements that reflect the scale, proportions, materials, and colors of other commercial buildings in the district. A new storefront should not imitate another building or have a false historical appearance.



1. Storefront Cornice
2. Transom
3. Upper Floor Entry
4. Pier
5. Storefront Door
6. Recessed Entry
7. Bulkhead
8. Storefront Window
9. Window Sign

A. PRESERVE AND MAINTAIN ORIGINAL STOREFRONTS AND THEIR CHARACTER-DEFINING FEATURES AND MATERIALS.

- > Retain the historic storefront configuration, including the original location and size of the entrance doors, display windows, and transoms.
- > Retain storefront features that are not original, but have gained architectural and historical value.
- > Retain and repair historic structural components, such as decorative cast iron elements and stone or brick piers.
- > Retain and repair historic entrance doors and any distinctive hardware.
- > Retain and repair historic transoms, especially those with prism or leaded glass.
- > Retain and repair original wood or brick bulkheads. Also, retain elements such as Carrara glass or glazed tile that have gained historic significance in their own right.
- > Retain and repair the historic cornice or sign band, which delineates the storefront from the upper facade.
- > Protect historic features and materials by maintaining their historic protective finishes, such as paint or stucco.



The recessed entrance and storefront cornice are character-defining features of this commercial building.



Preserve original transom materials, such as prism glass.

B. REPLACE STOREFRONT FEATURES THAT ARE MISSING OR DETERIORATED BEYOND REPAIR WITH COMPATIBLE ELEMENTS THAT MATCH THE ORIGINAL IN DESIGN, DIMENSION, TEXTURE, AND MATERIAL.

- > Replace display windows with new windows that fill the original opening and have wood, copper, or aluminum mullions. Dark anodized aluminum is preferred for new display windows rather than untreated aluminum frames. Untreated aluminum should be primed and painted if used.
- > Replace storefront glass with clear rather than tinted or reflective glass. Use an awning, canopy, or transparent low-E glass to reduce sunlight and heat gain.
- > Replace bulkheads with wood bulkheads or brick bulkheads, if they match the original brick of the building or are painted to complement other storefront elements.
- > Replace doors with wood doors with a single light of glass, as these are appropriate for most historic buildings in downtown Sumter. Metal doors with a dark bronze finish or an anodized aluminum finish may also be appropriate.
- > Use historic photographs and physical evidence to reconstruct a missing or insensitively altered feature, if documentation is available.
- > If photographs or physical evidence cannot be found, base the design on similar elements found on nearby historic properties, keeping the design of the replacement feature simple.



These appropriate wood replacement doors are single light.



The transom and bulkheads of this storefront are simple in design and are based on the scale, proportions, materials and colors of other commercial buildings in the district.

C. RECONSTRUCT A MISSING STOREFRONT TO MATCH THE CHARACTER, SCALE AND MATERIALS OF THE HISTORIC STOREFRONT.

- > Remove inappropriate materials covering the facade.
- > Conduct exploratory demolition to determine if any historic fabric remains and its condition.
- > Restore as many of the remaining historic elements as possible.
- > Use historic photographs and physical evidence to reconstruct a missing or insensitively altered storefront or feature, if documentation is available.

D. CONSIDER A SIMPLIFIED OR CONTEMPORARY INTERPRETATION OF A TRADITIONAL STOREFRONT WHERE THE HISTORIC STOREFRONT IS MISSING OR NO EVIDENCE OF IT EXISTS.

- > Base the new design on traditional storefront elements that reflect the scale, proportions, materials, and colors of other commercial buildings in the district.
- > Use compatible materials that are in keeping with the style of the building.
- > Avoid creating a false historical appearance by introducing architectural elements where they never previously existed.

E. MEET CODE REQUIREMENTS FOR ACCESSIBILITY IN A MANNER THAT HAS MINIMAL IMPACT ON THE CHARACTER-DEFINING FEATURES OF A STOREFRONT.

- > Avoid adding new entrances to the front of a building unless required by code.
- > Install additional means of access in a way that is reversible and that does not compromise the historic storefront design.
- > Use new doors that are simple in design with detailing to match existing doors of the building. Wood doors with single light glass are typically appropriate for most historic downtown buildings.



An example of a compatible new storefront in downtown Sumter.



Replacing an incompatible storefront with a new storefront based on traditional elements can enhance the appearance of the building and the district.

MORE INFORMATION

Preservation Brief #11

Rehabilitating Historic Storefronts

Preservation Brief #12

The Preservation of Historic Pigmented Structural Glass

Preservation Brief #27

The Maintenance and Repair of Architectural Cast Iron

Preservation Brief #42

The Maintenance, Repair & Replacement of Historic Cast Stone

DEFINITIONS

Bulkhead: Lower panels that support display windows, also referred to as kickplates. Common materials are wood and brick.

Carrara Glass: Pigmented structural glass often added to “modernize” storefronts in the 1920s and 1930s.

Transom: Rectangular windows added above display windows and door openings.

Cornice: Decorative trim, often of metal or wood, which delineates the storefront from the upper façade.

4.11 PAINT

The right combination of paint colors can accentuate important architectural features and unify the façade. In addition to its aesthetic benefits, paint also provides protection to certain building surfaces, particularly wood. Due to these protective qualities, building components that were historically painted should remain painted. Alternatively, surfaces that were not historically painted, such as brick and stone, should remain unpainted to retain their historic texture and appearance. Appropriate paint schemes differ depending on the architectural style and era of a building. Historically appropriate color schemes for a particular style can be determined based on paint analysis or research.

A. MAINTAIN AND REPAINT HISTORICALLY PAINTED SURFACES.

- > Remove paint from masonry only when the paint is not historic, will not reveal aesthetic issues, and will not damage the masonry.
- > Do not paint unpainted masonry walls unless insensitive past repairs have negatively affected the visual qualities of the masonry.
- > Do not strip paint or other coatings to reveal bare wood or apply a stain if the material did not historically have a natural finish.

B. SELECT A COMPATIBLE COLOR SCHEME.

- > Choose colors that are appropriate to the architectural style and complement the building and its surroundings. Overly bright and obtrusive colors are not appropriate.
- > Consider an original color scheme based on paint analysis or research.

C. USE PAINT COLOR TO ACCENTUATE EXTERIOR DETAILS.

- > Use dark or muted colors for the walls of a building.
- > Use lighter colors to highlight trim and architectural ornamentation.
- > Paint window sash and frames a contrasting color than the walls to provide contrast and depth to window openings.
- > Limit the paint scheme to three or four colors: one roof color, one wall color, one trim color, and one accent color.

D. REMOVE DETERIORATED PAINT USING THE GENTLEST MEANS POSSIBLE.

- > Do not use abrasive methods, such as sandblasting, high-pressure water, or butane torches to remove paint from masonry, wood, or metal.

MORE INFORMATION

Preservation Brief #10

Exterior Paint Problems on Historic Woodwork.

Note: City Council approved a general certification of appropriateness for paint colors in both districts, which was adopted by Ordinance. Planning staff may administratively approve exterior paint colors if selected from the approved color palette.

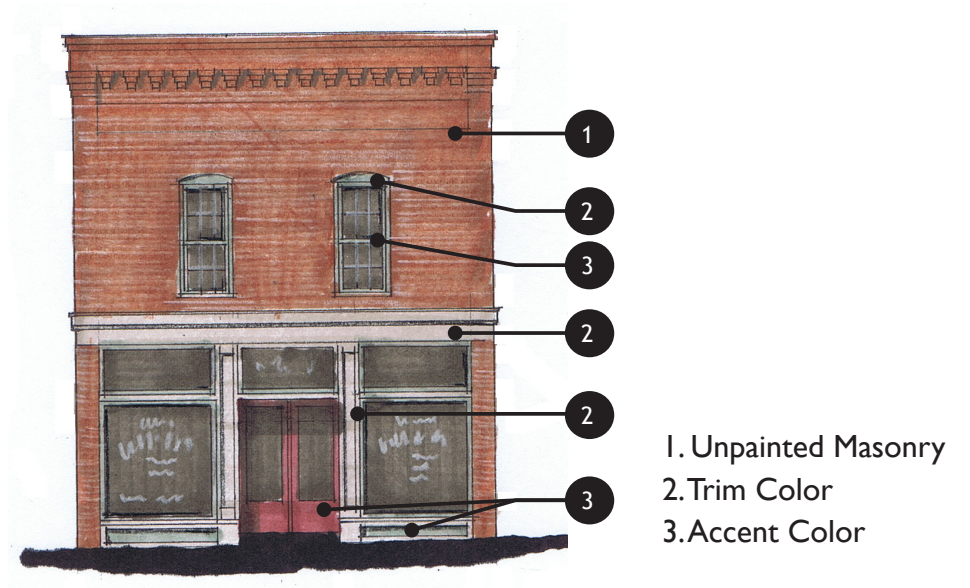
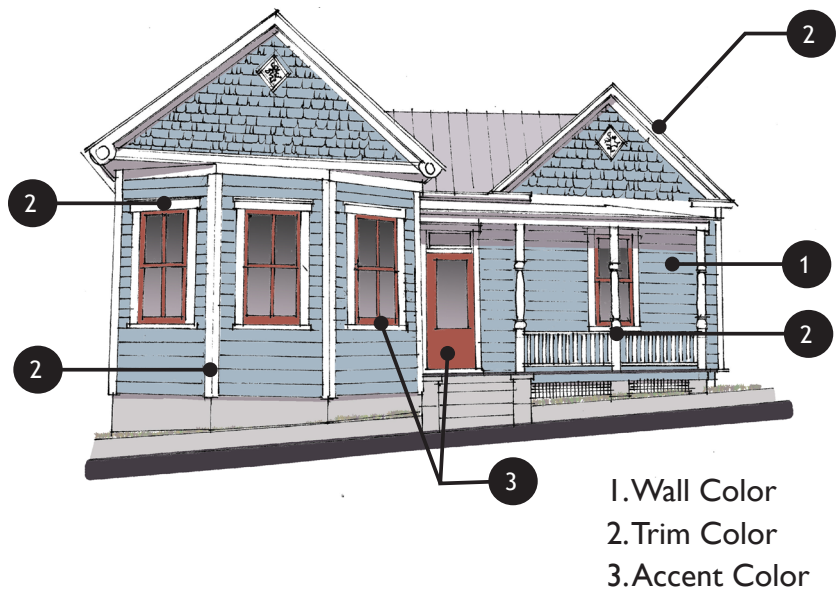

A fragmented color scheme detracts from the streetscape.



These two buildings successfully incorporate accent colors to emphasize key architectural features.

4.12 SIGNS & AWNINGS

Signs are important because they identify buildings and businesses, provide essential information, and attract customers. They can provide a unique business identity and add visual interest when placed appropriately on a building. Signs should be compatible with the architectural character of the building on which they are placed and with the surrounding historic district. A careful balance must be reached between the need to call attention to individual businesses and the appearance of the district as a whole. The presence of too many signs that are not well designed can result in visual clutter and detract from the district. Whether signs enhance or detract from a building or district depends on their design, placement, size, number, and condition. Factors such as size, color, typeface, content, lighting, and choice of materials should all be considered carefully.

A. PLACE SIGNS IN A MANNER THAT IS COMPLEMENTARY, OR SUBORDINATE TO, THE ARCHITECTURE OF THE BUILDING.

- > Locate signs on flat, unadorned areas, such as horizontal sign bands, existing signboards, or vertical piers.
- > Place signs at or below the storefront cornice for a ground level business.
- > Position permissible portable signs so that they do not interfere with pedestrians or traffic sight lines at intersections.
- > Do not use freestanding or monument signs in the Downtown Historic District.

B. ATTACH SIGNS IN A MANNER THAT WILL NOT DAMAGE OR OBSCURE ARCHITECTURAL FEATURES.

- > Minimize the number of sign attachments to a building.
- > Avoid obstructing or damaging character-defining features, which include, but are not limited to: a storefront or building cornice, decorative or patterned masonry, or window and door trim.
- > Attach signs in mortar joints rather than drilling holes in brick, stone or concrete walls.
- > Use attractive hardware and supports of finished metal or wood to mount signs, particularly projecting signs.
- > Take advantage of the locations of former signs to minimize additional impact on the building by attaching new signs, where appropriate.



Use attractive supports and hardware to mount projecting signs.

SIGN TYPES

Window Signs are painted on or applied to window or door glazing.

Wall Signs or Attached Signs are panels or individual letters mounted to the wall or frieze of the storefront cornice.

Awning or Canopy Signs are painted, printed, sewn, or attached onto the valence or slope of the awning or canopy.

Projecting Signs are mounted perpendicular to the face of the building and are generally double-sided.

Suspended Signs are mounted parallel or perpendicular to the face of the building and are generally double-sided.

Freestanding Monument Signs are mounted on the ground, to posts, or other supports and placed in front of buildings that are set back from the street. They are typically appropriate in the front yard of a residence that has been converted for commercial or office use.

Portable Signs, such as sandwich boards, can be easily moved from one location to another.

Temporary Signs, such as banners, are typically fabric of some type and suspended from the building wall.

All signs must comply with the regulations set forth in Section 8.H of the Sumter Zoning and Development Standards Ordinance. Check these regulations first to determine the minimum and maximum requirements for signage. Historical markers and professional name plates that do not exceed two square feet are exempt from review and do not require a sign permit.

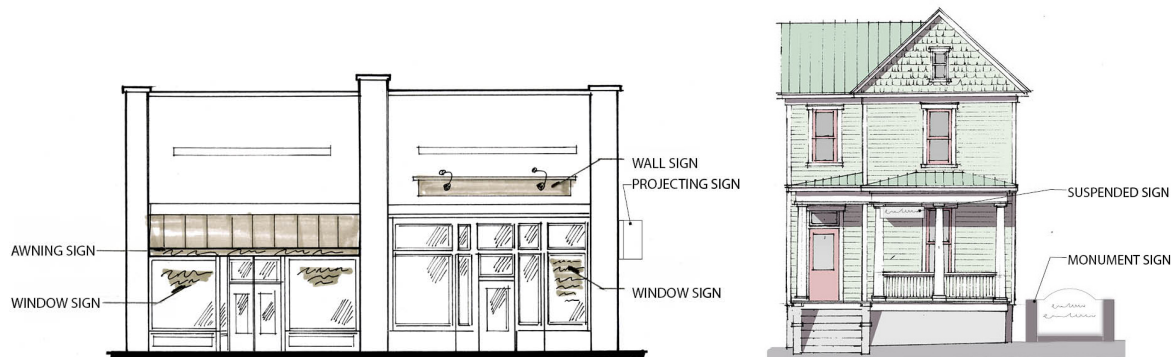

C. LIMIT THE SIZE AND NUMBER OF SIGNS PER BUILDING.

- > Limit sign area to less than 25 percent of the building front wall.
- > Relate sign proportions to the element on which it is placed.
- > Size the lettering and graphics of window signs to be clearly legible, but not block views into or from display windows.
- > Limit the size of transom signs to avoid blocking light to the interior or obscuring the transom glazing.
- > Use signs that are pedestrian oriented and of a scale comfortable for a walking customer.

D. USE APPROPRIATE MATERIALS THAT COMPLEMENT THE STYLE AND MATERIALS OF THE BUILDING.

- > Use traditional sign materials (finished wood, glass, metal, brass letters) or contemporary products that have the same visual characteristics.
- > Finish sign edges to provide character and durability.
- > Limit the use of neon signs to the interior of buildings. Neon signs on building exteriors are not appropriate.
- > Shiny plastic products, including internally-illuminated, plastic box signs are not appropriate.
- > Avoid painting signs directly on unpainted masonry walls.

E. USE COLORS THAT COMPLEMENT THE BUILDING, INCLUDING ACCENT AND TRIM COLORS.

- > A maximum of three colors is recommended per sign, although more may be appropriate in some cases.
- > Use colors that relate to the overall color scheme of the building.
- > Use light or neutral colors on window signs—such as white or gold leaf—that are easy to read.
- > Minimize solid painted background behind window lettering, as it reduces transparency.



Use traditional sign materials or contemporary products with similar visual characteristics.

F. DESIGN SIGNS TO BE SIMPLE AND LEGIBLE.

- > Keep sign message simple, easy to read, and in scale with the building and elements on which it is placed.
- > Avoid lettering that is difficult to read or overly intricate.
- > Use no greater than two or three distinct typefaces.
- > Consider the use of a symbol and logo rather than words.

G. PRESERVE AND MAINTAIN HISTORIC WALL SIGNS.

- > Retain historic signs that relate to the historic name of the building or signs that have acquired cultural significance over time.
- > Restore a historic painted wall sign with paint colors to match the original.

H. SUBMIT A COMPREHENSIVE SIGN PLAN FOR MULTI-TENANT BUILDINGS.

- > Place a sign that identifies the entire building, rather than individual tenants, in a central location or at the main entrance.
- > Place signs for individual stores or offices near their entrances or storefronts.
- > Use one wall-mounted directory sign at the primary entrance to collectively identify all occupants if there are several businesses in one location with a common entrance.
- > Locate a small projecting sign or wall-mounted sign adjacent to the entry door for an upper story business.



Historic signs can include painted wall signs and signs that identify the original name of building or building owner.



This window sign does not obscure the storefront, allowing for views of store merchandise.



A directory sign at the main entrance can be used to identify all tenants.

I. ENSURE THAT SIGNS IN THE RESIDENTIAL HISTORIC DISTRICT ARE COMPATIBLE WITH THE CHARACTER OF THE BUILDING AND SURROUNDING DISTRICT.

- > Wall signs, projecting signs, and freestanding monument signs may be appropriate for residences converted to commercial use.
- > Attach projecting signs to the porch entablature, parallel to the front of the building, or from a bracket or porch column, perpendicular to the face of the building.
- > Located wall signs adjacent to the front entrance.
- > Use freestanding monument signs for buildings that are set back from the street.
- > Integrate freestanding monument signs into the yard and streetscape by using plantings around the base.
- > Limit the height of freestanding monument signs to five feet or less.

J. CHOOSE SIMPLE, COMPATIBLE LIGHTING FIXTURES TO ILLUMINATE SIGNS.

- > Illuminate signs indirectly with a shielded light source.
- > Install fixtures and associated wiring inconspicuously to avoid detracting from the appearance of the building and without obscuring or damaging historic materials and features.
- > Limit internal illumination to a system that backlights individual letters only.
- > Use of electronic message board signs is not appropriate.



Freestanding signs are appropriate in residential areas for house converted to commercial use.



Sign illuminated indirectly with shielded light source.



Retractable awnings allow for greater visibility of storefront features.



Traditional awnings provide shade and opportunities for signage.

K. PRESERVE AND MAINTAIN HISTORIC AWNINGS AND CANOPIES.

L. CONSIDER A TRADITIONAL AWNINGS FOR SIGNAGE OR SHADE.

- > Size awnings to adequately fit commercial storefronts and window, door or porch openings of residential buildings.
- > Locate awnings on the transom bar or below the storefront cornice, above the transom, for commercial buildings.
- > Proportion the awning to allow for ample sidewalk clearance and projection over the sidewalk in downtown.
- > Choose an appropriate awning shape. Standard sloped awnings are appropriate in most cases, but circular or accordion designs can also be acceptable.
- > Choose appropriate awning fabrics, such as canvas, vinyl-coated canvas, and acrylic as awning materials. Metal and vinyl awnings are not appropriate.
- > Ensure the materials and colors are compatible with the design and color scheme of the building.
- > Consider using the awning valance as a sign panel for commercial buildings.
- > Consider retractable canvas awnings.

MORE INFORMATION

Preservation Brief #44

The Use of Awnings on Historic Buildings, Repair, Replacement and New Design

PAGE LEFT INTENTIONALLY BLANK

5

SITE DESIGN

Site design pertains to the relationship between a historic building and its site features. While incidental to the main building, site features do contribute to the overall character of a property. Collectively, buildings and site features along a street combine to create the streetscape. Traditional site features can include trees and plantings, fences and walls, driveways and walkways, and historic outbuildings. More modern site features, such as parking lots, site lighting and mechanical equipment, should be considered carefully for their impacts on the historic streetscape. For detailed requirements on the site features discussed in this chapter, consult the City Zoning and Development Standards Ordinance.

PAGE LEFT INTENTIONALLY BLANK

5.1 TREES AND PLANTINGS

Trees and plantings enhance the visual character of a building and the districts as a whole. It can also provide shade, block wind and generally soften the appearance of an urban streetscape. While the following guidelines for trees and plantings are recommended practices, they are not enforced by the HPDRC.

A. MAINTAIN HISTORIC TREES AND PLANTINGS.

- > Protect and retain existing trees and plants wherever possible.

B. DEVISE A PLANTING SCHEME THAT COMPLEMENTS THE BUILDING AND THE OVERALL DISTRICT.

- > Design landscaping to be secondary to the historic building.
- > Do not use large trees and plants that will conceal or obscure the primary elevation.
- > Use low plants and shrubs along sidewalks and walkways.
- > Use plant materials native to Midland South Carolina to ensure their health and longevity.
- > Plant trees and bushes several feet away from the foundation of a building to prevent root damage and moisture infiltration.



Street trees are pedestrian friendly and provide shade.



Low hedges or planters with flowers are appropriate along downtown sidewalks.



Appropriate plantings can visually enhance a property.

5.2 FENCES AND WALLS

Fences and walls delineate property boundaries, as well as distinguish private from public outdoor space. In Hampton Park, front yards are traditionally open to the street, with a fence enclosing the backyard for privacy. Low retaining walls exist where the front yard is above the grade of the sidewalk. These walls provide a clear termination of the yard, help to prevent erosion, and add decorative features to the front of the house. Retaining walls can be of stone or brick construction, or rock faced hollow core concrete blocks.

A. PRESERVE AND MAINTAIN HISTORIC FENCES AND RETAINING WALLS.

B. CHOOSE NEW FENCING THAT ENHANCES THE ARCHITECTURE OF THE BUILDING.

- > Select a fence design that relates to the style and character of the building.
- > Use traditional materials to build new fences or use appropriate contemporary materials with a traditional appearance.
- > Limit front yard fencing to open designs, such as painted wood picket or a simple wrought iron fencing, that will not obscure views of the building from the street.
- > In downtown commercial locations, use simple, low metal fencing in an open design that will not obscure views of the building from the street.
- > Avoid incompatible fencing—such as wood plank, split rail, vinyl, solid brick, or chain link fences—along prominent, visible property lines. Wood plank fences and solid wall brick fences may be added on the side property lines of corner lots adjacent to the street.
- > Do not use split rail fences in the historic districts.
- > Use ivy, vines, or other plant materials to cover or screen chain link fences.

- > Do not exceed fence heights of 4 feet on the front property line and 6 feet on side and rear yards.

C. BUILD NEW RETAINING WALLS WHERE NECESSARY.

- > Use stone or brick for new retaining walls. Brick can be reinforced, fully bonded or masonry veneer over reinforced concrete block.
- > Do not use poured concrete, exposed concrete block, wood timbers or crossties for new retaining walls.



A low wall accented with plantings provides a border between the private lot and the public sidewalk.



A low metal fence with brick piers defines the lot line, but does not obscure views of the house and yard.

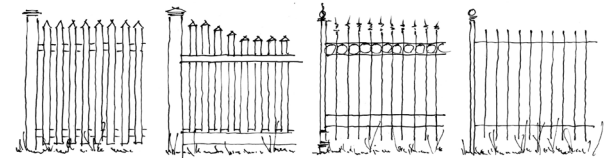
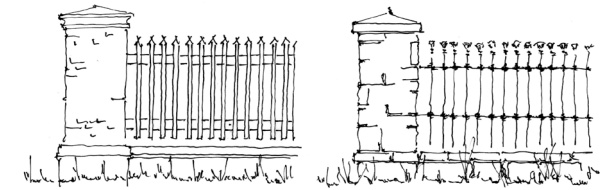

Wood Picket Fences

Decorative Wrought Iron Fences

Examples of appropriate front yard fencing.



The brick piers continue the street wall while the open metal pickets allow views to the courtyard beyond.



This low fence with painted wood pickets coordinates with the color and materials of the house.

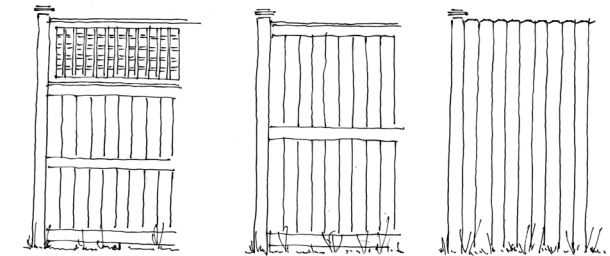

Examples of 6' privacy fences for rear yards.

5.3 DRIVEWAYS, WALKWAYS AND RAMPS

Driveways and walkways extend from the public streets and sidewalks, providing a transition to private properties in Hampton Park. Driveways in the district, which are usually linear, tend to measure five to ten feet wide and are either solid concrete or concrete with grass median strips. Built parallel to the sides of residences, some driveways extend to garages or other accessory buildings at the rear of lots. Walks link the front porch or stoop to the sidewalk. Most walks in Hampton Park are composed of concrete, flagstone or brick pavers. Access ramps are sometimes needed when a house does not have an at-grade entrance. Ramps can be added in a sensitive manner that retains the historic and architectural character of a building.

A. MAINTAIN TRADITIONAL DRIVEWAY CONFIGURATIONS.

- > Retain and repair historic driveways and their materials.
- > Locate new driveways to the side or rear of a building.
- > Maintain narrow driveway widths to reduce their visual impact.
- > Use paving materials that complement the architectural style of the house.

B. MAINTAIN TRADITIONAL WALKWAY CONFIGURATIONS.

- > Retain and repair historic walkways and their materials.
- > Use paving materials that complement the architectural style of the house.
- > Use the same materials for driveways and walkways to maintain design consistency.



Concrete driveway with a grass median strip.



Meandering brick walkway.

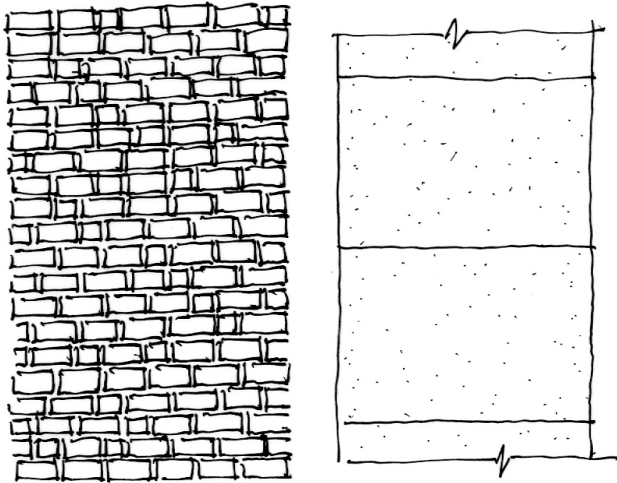

Brick pavers and poured concrete are appropriate walkway materials.

C. MINIMIZE THE VISUAL EFFECT OF ACCESS RAMPS.

- > Design access ramps to have a minimal visual effect on the building and/or setting.
- > Locate handicap ramps on rear or the least visible side elevation, where possible.
- > Avoid locating handicap ramps on the front elevation.
- > Use materials that are compatible with the existing materials of the building.
- > Design access ramps so not to damage historic features and to be reversible.



Sensitive access ramp design that approaches from side of house.

5.4 PARKING AREAS

Available and accessible parking is important to business patrons in the Downtown Historic District and the residents of Hampton Park. However, the visual impact of off street parking areas can be significant. The careful design and placement of parking lots is imperative for retaining the historic character of both historic districts.

A. MINIMIZE THE VISUAL IMPACT OF PARKING AREAS.

- > Locate parking behind a building to reduce its visual impact.
- > Screen parking lots from view at street frontages and property lines with plants and/or walls and fences.
- > Reduce the scale of a large parking area with defined planting beds to break down the lot into smaller sections.
- > In the Downtown Historic District, continue the setback and rhythm of the streetscape with landscape elements, such as trees, hedges or fences of brick or wood along the edge of the lot.
- > In Hampton Park, separate parking areas from the street right-of-way and property lines by a landscaped strip at least ten feet in width.
- > Follow the minimum parking requirements set forth in the Zoning Ordinance.
- > Use paving materials that are compatible with the character of the district.

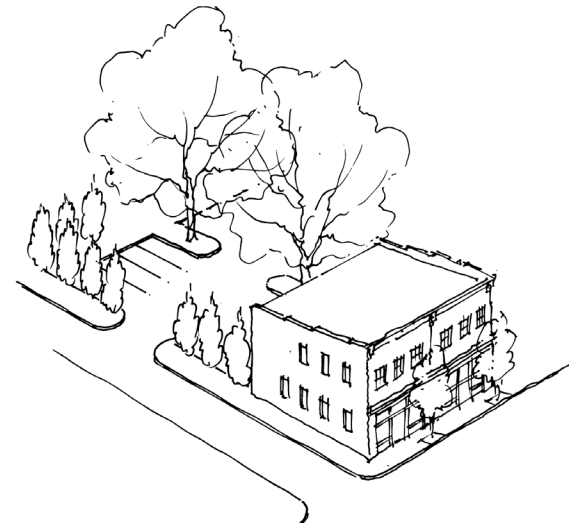

Locate parking behind buildings and provide screening to reduce impact.



Brick piers and metal fencing continue the setback and rhythm of the downtown streetscape.

5.6 LIGHTING

Outdoor lighting in the Downtown Historic District and Hampton Park is important for safety and security. Exterior light fixtures can either be attached to the building or be freestanding, such as the street light poles in the downtown district furnished by the City. Historic light fixtures can be an important part of a building's character. While some buildings retain their historic light fixtures, others do not. Selecting suitable lighting requires careful consideration, as it can affect both the daytime and nighttime appearance of a building.

A. RETAIN HISTORIC LIGHT FIXTURES AND REPAIR THEM WHEN POSSIBLE.

B. CHOOSE LIGHT FIXTURES THAT ARE COMPATIBLE WITH THE CHARACTER OF THE HISTORIC BUILDING AND THE OVERALL DISTRICT.

- > Select light fixtures that are appropriate to the style and era of the building.
- > Choose contemporary fixtures in simple designs when an appropriate traditional fixture cannot be found.
- > Limit exterior lighting to that necessary for convenience and safety.
- > Choose fixtures that are of an appropriate scale for the building.
- > Locate new fixtures and wiring in an unobtrusive manner that does not obscure or damage historic materials or features.
- > For residential buildings, mount new light fixtures to the porch ceiling or adjacent to the primary entrance. Consider small footlights for walkways and driveways.
- > For commercial properties, conceal the light source by using recessed ceiling fixtures, angled fixtures, or shaded fixtures to prevent glare.

- > Use light of an appropriate color quality that preserves the natural colors of objects and features.
- > Locate higher intensity security lighting on rear or secondary elevations that are not visible from the street.



These original light fixtures contribute to this building's character.



Consider small footlights for walkways and driveways.



These simple, unobtrusive light fixtures are mounted to the porch ceiling.

5.7 OUTBUILDINGS AND ACCESSORY STRUCTURES

Garages and other accessory structures contribute to the historic fabric of a neighborhood, especially when they have retained their historic character. In Hampton Park, outbuildings historically included stables for horses and carriages and later, garages for automobiles. Many historic outbuildings are of wood frame construction with exterior wall cladding and trim to match that of the main house. When designing a new garage or accessory structure, it is important to remember that its design and placement will affect the overall appearance of the property. A thoughtful design will ensure that the new building is compatible with the house and the district as a whole.

A. MAINTAIN AND PRESERVE HISTORIC OUTBUILDINGS.

- > Retain and repair original sheds and garages following the Maintenance and Rehabilitation Guidelines in Chapter 4.

B. DESIGN NEW OUTBUILDINGS TO COMPLEMENT THE PRIMARY BUILDING.

- > Design new outbuildings to be subordinate to the primary building in size, scale, and location.
- > Locate new outbuildings in inconspicuous locations, set behind the primary building, preferably at the rear of the lot.
- > Ensure that new outbuildings are compatible with the main house in size, scale, materials, and roof slope.
- > Include a separate opening for each vehicle in a multi-bay garage.
- > Limit the visibility of pre-fabricated accessory structures as much as possible.

C. CONFINE RECREATIONAL STRUCTURES AND FACILITIES TO REAR YARDS.

- > Situate swimming pools, tennis courts and other recreational structures at the rear of a property, in a location not visible from the street.
- > Screen recreational structures from view with an appropriate fence or landscaping.



The exterior wall cladding and trim of this garage matches the main house.

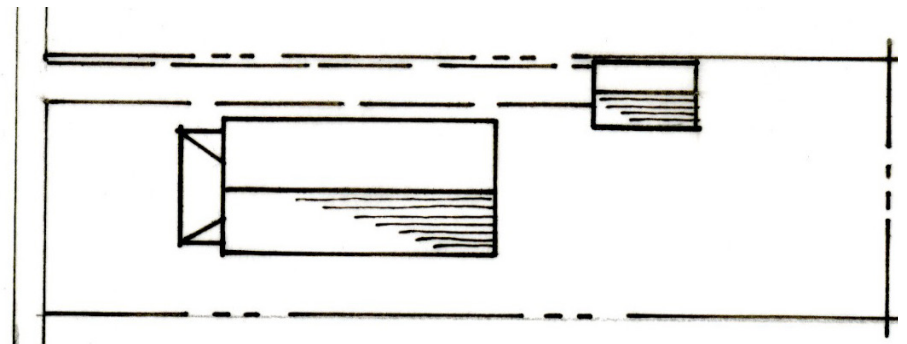

Site new garages behind the house, in an inconspicuous location.

5.8 MECHANICAL AND UTILITIES SCREENING

Contemporary site appurtenances, such as mechanical units, solar panels, satellite dishes, and trash containers can detract from the appearance of a historic property and the entire district if not sensitively placed.

A. PLACE SITE APPURTENANCES IN DISCREET LOCATIONS TO DIMINISH VISUAL IMPACT.

B. MINIMIZE THE VISIBILITY OF MECHANICAL EQUIPMENT.

- > Place HVAC condensers at the rear of the building or on secondary elevations that are not visible from the public right of way.
- > Screen visible mechanical equipment located at grade with wood or brick fencing, lattice panels, or landscaping.
- > Do not place mechanical equipment on roofs of residential buildings.
- > Install window air conditioning units on the rear elevation or side elevations that are not visible from the public right of way.

C. MINIMIZE THE VISIBILITY OF SOLAR PANELS.

- > Locate solar panels in the backyard or on rear rooflines when possible.
- > Avoid prominent locations in the front yard or on the front of a building.
- > Install solar panels flush with the roof and follow the roof slope.

D. MINIMIZE THE VISIBILITY OF SATELLITE DISHES AND ANTENNAS.

- > Site satellite dishes, antennas and other signal receiving devices in rear or minimally visible side yards.
- > Screen satellite dishes from public view with landscaping or fencing.

PAGE LEFT INTENTIONALLY BLANK

6

NEW CONSTRUCTION & ADDITIONS

Designing a compatible new building or addition in a historic district is a challenging task that requires careful thought and an understanding of the historic context. The variety of building types and architectural styles in Sumter reflect the different periods of development in the history of the city. Since new construction continues this evolution of the built environment, its design should be a product of its time. Successful new construction does not attempt to reproduce historic styles, but rather is contemporary in design, while being compatible with its context by taking cues from the elements and materials of surrounding buildings. New construction designed to respect rather than compete with the historic setting accomplishes the goal of preserving the architectural character of a district. Because the historic districts of Sumter each have their own unique characteristics and vocabularies, compatible new construction and additions will vary depending on the specific context. As such, a design that is appropriate for one location may not be appropriate for another. The guidelines in this chapter provide the general design framework for new construction and additions while allowing the flexibility to create innovative buildings that are compatible with their historic settings.

PAGE LEFT INTENTIONALLY BLANK

6.1 COMMERCIAL PROPERTIES

High quality infill construction on vacant or underutilized lots has the potential to strengthen the vitality and restore the density of the Downtown Historic District and, over time, contribute to its evolving architectural character. Existing historic downtown buildings represent a variety of different building types and architectural styles. Most notable of these styles are Richardsonian Romanesque, Neo-Classical Revival, and Main Street Commercial. While downtown buildings differ in their detailing and level of ornament, certain patterns are consistent among them, such as their siting, size, and the general alignment of storefronts, upper story windows, and cornices. The intent of these guidelines is to encourage new buildings that reinforce and respond to the principal design elements of historic commercial buildings in the district, while reflecting their own time in the development of the city.

A. DESIGN NEW BUILDINGS TO REFLECT THEIR OWN TIME.

- > Avoid the direct imitation of a historic style that would blur the distinction between old and new.
- > Avoid any reference to historic styles that precede the growth and development of the district.



Although architectural styles may vary, the general alignment of storefronts, upper story windows, and cornices contribute to the visual continuity of the Downtown Historic District.



Sumter's period of growth and development occurred after the Civil War, which is reflected in the character of the commercial buildings in the Downtown Historic District

B. INCORPORATE THE PRINCIPAL ELEMENTS OF TRADITIONAL COMMERCIAL FACADES INTO THE DESIGNS OF NEW BUILDINGS.

- > Integrate the design features of traditional storefronts on the first floor. Use contemporary construction materials to avoid creating a false historic appearance.
- > Delineate between the storefront level and upper floors with elements of horizontal expression, such as a canopy, belt course, steel lintel, molding, or cornice.
- > Use vertically proportioned upper story windows in a regular pattern and an appropriate ratio of solid wall to window area.
- > Provide visual termination at the top of the building with a cornice, parapet, pediment or other decorative feature.

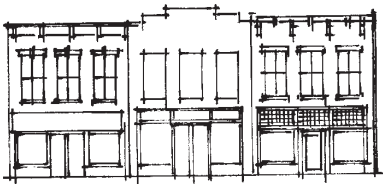

This example incorporates traditional elements of a traditional commercial facade, including a distinct base, middle and top, which continues the rhythm of the existing buildings on the block.



This example, with its unbalanced window and door configuration, does not incorporate the elements of a traditional commercial facade and disrupts the rhythm of the streetscape.

See Section 4.8 for additional information on the components of traditional commercial storefronts.

SETBACK, ORIENTATION AND SPACING

Commercial buildings in the Downtown Historic District align uniformly with the street, flush with the sidewalk and adjacent buildings, creating a consistent street wall that is a defining feature of the historic district. Most commercial buildings in the district have no setback, maximizing the exposure and visibility of the primary elevation. Little to no spacing between commercial buildings coupled with the orientation of building fronts to the street further define and reinforce the street wall.

C. REINFORCE THE STREET WALL BY RELATING SETBACK, ORIENTATION AND SPACING OF NEW CONSTRUCTION TO THAT OF EXISTING BUILDINGS.

- > Align new commercial construction with the property line without setbacks or side alleys.
- > Minimize gaps in the street wall created by new buildings.
- > Allow deeper setbacks with landscaped areas or pocket parks only for buildings constructed on the edges of the district or for new governmental or institutional buildings where appropriate to emphasize their civic function.
- > Orient the front of a new building to the primary street onto which the lot faces.

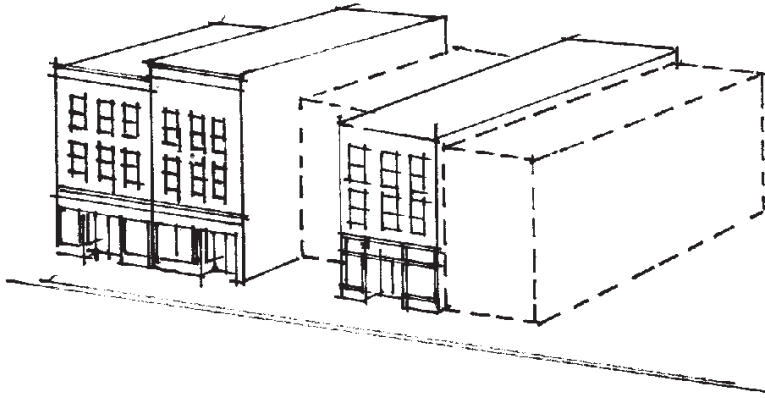

New construction that protrudes or recedes back from adjacent buildings interrupts the street wall.



These new commercial buildings in Sumter are flush to the sidewalk with no front setback.

SIZE, SCALE AND MASSING

The height and width of buildings fluctuate on most downtown blocks, as building sizes somewhat vary. These slight variations in building size add character and visual interest to the district. The scale of these buildings, however, is relatively consistent as the district has few buildings taller than three stories. Most occupy narrow lots, are simple and rectangular in form, and extend vertically with multiple stories. The relationship of a new building to adjacent historic buildings in terms of size and scale establishes its compatibility within the block or district. Buildings that deviate from the predominant size and scale of other buildings on the street can negatively affect the district if sensitive massing and transitions are not part of their design. The massing of larger new construction can be designed to retain the general scale of the historic buildings in the district, especially as perceived from street level.



Downtown building heights and Sumter vary, but few buildings are taller than three stories

MORE INFORMATION

DEFINITIONS

Size: Determined by the two dimensional measurement of the height and width.

Scale: Refers to the relationship between two or more objects. In architecture, scale can refer to the relationship of the human form to a building or the relationship of one building to another.

Massing: Perception of the general shape and form as well as the size of a building.

D. DEVELOP RESPECTFUL RELATIONSHIPS IN TERMS OF SIZE, SCALE AND MASSING TO ADJACENT HISTORIC BUILDINGS.

- > Construct new buildings that are similar in height and width to adjacent buildings. These proportions may vary depending on the character of each block.
- > Reduce the perceived mass of a large new building by dividing its height or width into smaller masses that relate to the proportions of adjacent buildings.
- > Step back or cascade portions of new buildings that are taller than adjacent buildings away from the street front to maintain the traditional range of heights at the street edge.
- > Relate the base of a new building that is significantly taller than its neighbors to the heights of adjacent buildings.
- > Preserve view sheds for significant local focal points, as well as major streets and pedestrian pathways.



Compatible infill conforms to the predominant story height and building width and proportion of existing buildings on the block. For wide lots, use vertical divisions to divide a building into bays of appropriate width that will retain the historic scale of buildings in the district.



The base of this high-rise building relates to its neighbors while the upper stories are stepped back to reduce visual impact on the streetscape.

E. ESTABLISH AN APPROPRIATE SCALE FOR NEW BUILDINGS THAT IS COMPATIBLE WITH THE CHARACTER OF THE DISTRICT.

- > Reflect the widths and bay divisions of other historic buildings along the block.
- > Incorporate evenly spaced vertical divisions to divide a wide building into bays of appropriate widths to reduce the scale.
- > Avoid the use of strong horizontal lines, especially for buildings that exceed the average width of adjacent buildings on the block.
- > Create visual interest at the ground level to emphasize the human scale of the building by incorporating functional elements like traditional storefronts and entrances.

ROOF FORM

The roof plays an important role in defining the form of a building. The majority of buildings in the Downtown Historic District have shed roofs that slope to the rear of the building and hide behind a parapet wall.

F. CHOOSE A ROOF FORM THAT IS SIMILAR TO THOSE OF TRADITIONAL COMMERCIAL BUILDINGS IN THE HISTORIC DISTRICT.

- > Avoid roof types that become prominent visual features of the building.
- > Use a parapet wall to screen satellite dishes or rooftop mechanical equipment.

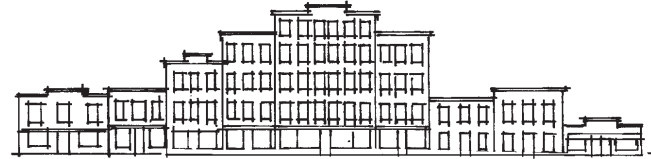

Although both buildings are the same height and width, the perceived scale of the top example is reduced by dividing its height and width into smaller masses that relate to the proportions of adjacent buildings. The bottom example reads as a single volume and looks out of scale.



The new infill construction continues the rhythm and pattern of windows and storefront openings on the block.

WINDOW AND DOOR PATTERNS

The style and character of a building, as well as its scale, are characterized to a great extent by the size, proportion and articulation of door and window openings. The ground floors of most downtown commercial buildings are largely transparent, incorporating large panes of glass separated by narrow columns. The use of tall doors with transoms is common to allow additional light into the space and to align entrances with the tops of the display windows. Main entrances in the district are oriented to face the street and often recessed within the storefront to provide shelter. The upper floors generally have a larger area devoted to solid wall surface than to windows. These window openings are uniform in size, spacing and alignment and are typically vertically proportioned. Windows on masonry buildings are usually recessed rather than flush with the wall surface.

G. ARRANGE WINDOWS AND DOORS TO REFLECT THE TRADITIONAL SIZE, PROPORTION, SPACING, RHYTHM AND ALIGNMENT OF OTHERS IN THE DISTRICT.

- > Keep the proportion of window to wall area for both upper and lower facades compatible to that of existing buildings.
- > Incorporate a ground floor storefront into the design of a new building. A contemporary design can be appropriate if based on traditional storefront features and if it is compatible with the visual character of the district.
- > Orient the primary entrance of the building to the street.
- > Recess the main entrance if it continues an established pattern on the block.
- > Continue the general alignment, spacing, size, profile and proportion of the upper floor windows of adjacent buildings in new construction.
- > Use traditional styles found in the district as the basis for new doors and windows.

ARCHITECTURAL DETAIL AND ORNAMENTATION

In the Downtown Historic District, the level of architectural detail and ornamentation varies depending on the style and period of a building. Commercial buildings in downtown feature decoration such as cornices, brackets, window and door trim, and patterned masonry. Successful new construction does not attempt to reproduce historic detailing, but will rather reinterpret traditional decorative features in a fresh, contemporary manner.

H. REINTERPRET TRADITIONAL DECORATIVE ELEMENTS IN A CONTEMPORARY MANNER.

- > Incorporate simplified architectural features that reflect, but do not duplicate, similar features found on existing historic buildings in the district.
- > Concentrate architectural detail in areas that traditionally featured detail, such as floor transitions, window surrounds, and cornices or pediments.
- > Use detail that is three dimensional to add visual interest and texture to the façade.



This example of new construction in Roanoke, Virginia reinterprets traditional architectural details in a way that reflects, but does not duplicate them.

MATERIALS AND COLOR

Masonry is the predominant exterior wall material in the downtown district. While brick is most common, there are also examples of buildings clad in concrete, stone, and terracotta. The use of wood in the downtown district is limited to windows, doors, storefronts, and exterior details. A few buildings also feature metal cornices and facades. Compatibility with traditional materials can be achieved without directly replicating their use in new construction. Materials for new construction do not necessarily need to be the same as the traditional materials found in the historic district, but they should be harmonious.

I. CHOOSE MATERIALS THAT ARE HARMONIOUS WITH TRADITIONAL MATERIALS FOUND IN THE HISTORIC DISTRICT.

- > Select materials that are visually compatible with and complementary to the architectural character of the district and surrounding buildings.
- > Use high quality materials with proven durability in the local climate.
- > Choose materials with a similar scale, color, texture, and finish as those used historically in the district.
- > Contemporary materials that are compatible with historic materials may be acceptable if the material conveys the visual qualities of traditional materials.
- > Employ a uniform primary wall material on all sides of the building. Use of a limited number of different materials may be appropriate if a building is broken up into separate masses.

J. SELECT A COORDINATED COLOR PALETTE INFORMED BY HISTORIC PRECEDENT AND COMPATIBLE WITH ADJACENT BUILDINGS AND THE DISTRICT AS A WHOLE.

ADDITIONS

Exterior additions to historic buildings in the downtown district can provide valuable additional space to accommodate new uses or growing businesses. However, insensitively designed additions can radically alter the historic appearance of the building and destroy important features. Careful design and location of new additions can complement rather than detract from the character of a historic building and the district as a whole.

K. DISTINGUISH A NEW ADDITION FROM THE HISTORIC BUILDING WITH A SIMPLE AND UNOBTRUSIVE DESIGN.

- > Design an addition to be subordinate to the existing building in size, design and detailing.
- > Locate a new addition on the rear elevation where not highly visible from the public right of way.
- > Design rooftop additions so not to be visible from the street and to be minimally visible from other vantage points in the district by setting them at least one full bay back from the primary elevation and other street walls.
- > Devise a distinct but compatible appearance if an addition has its own street frontage.
- > Include simplified architectural features derived from similar features on the historic building.
- > Base the size, rhythm and alignment of the window and door openings on those of the historic building.
- > Ensure that colors and materials are harmonious with the materials of the historic building.

- L. AVOID OBSCURING OR DESTROYING IMPORTANT FEATURES OR MATERIALS OF THE EXISTING BUILDING WHEN CONSTRUCTING AN ADDITION.
- M. DESIGN AND CONSTRUCT AN ADDITION SO IF REMOVED IN THE FUTURE THE BASIC FORM AND CHARACTER OF THE ORIGINAL BUILDING REMAIN INTACT.

MORE INFORMATION

Preservation Brief #14

New Exterior Additions to Historic Buildings: Preservation Concerns



Located on the rear elevation, this addition is contemporary in design to distinguish it from the original building.

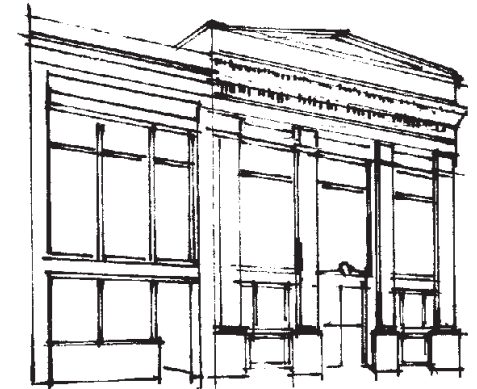

The addition is subordinate to the original building with simplified features that reflect, but do not duplicate, the historic building.

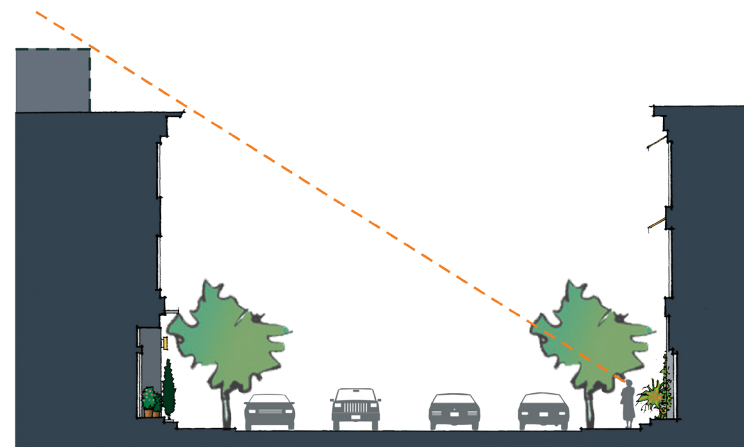

This diagram shows how a rooftop addition can successfully be set back from the front of a three-story building with little impact on the building or the district.

6.2 RESIDENTIAL PROPERTIES

High quality infill construction on vacant or underutilized lots has the potential to strengthen the vitality of the Hampton Park Design Review District, and over time, contribute to its evolving architectural character. Existing buildings in the residential historic district represent a variety of architectural styles and forms. While these buildings differ in their detailing and level of ornament, certain patterns are consistent among them in terms of their siting and appearance. The intent of these guidelines is to encourage new buildings that reinforce and respond to the principal design elements of historic houses in the district, while reflecting their own time in the development of the city.

A. DESIGN NEW BUILDINGS TO REFLECT THEIR OWN TIME.

- > Avoid the direct imitation of a historic style that would blur the distinction between old and new.
- > Avoid any reference to historic styles that precede the growth and development of the district.

B. INCORPORATE THE PRINCIPAL ELEMENTS OF TRADITIONAL RESIDENTIAL CONSTRUCTION INTO THE DESIGNS OF NEW HOUSES.

- > Design non-residential buildings in the district to be compatible with neighboring residential buildings, but easily recognizable as office, commercial or institutional uses.
- > Avoid making non-residential buildings look like residential buildings.



Before moving forward with a construction project, identify the primary characteristics of the neighborhood, including architectural styles, porches, roof form, window patterns, materials, orientation, building mass, and setbacks.

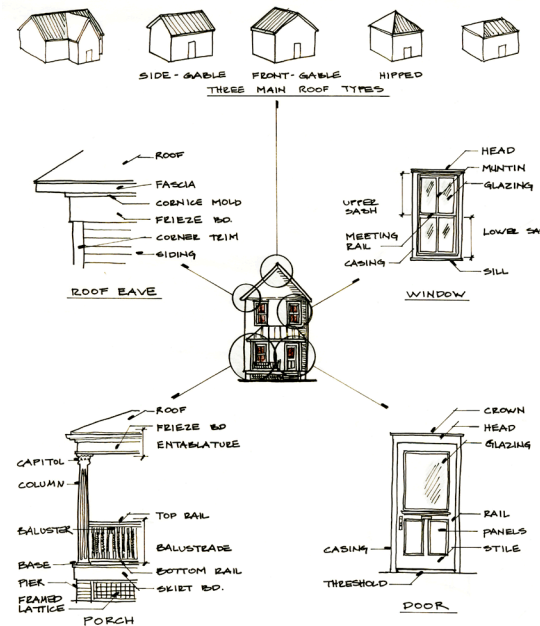

Gain an understanding of traditional components of residential construction prior to designing and building a new house.

SETBACK, ORIENTATION AND SPACING

Setback refers to the distance between the building wall and the property line or public right-of-way at the front of the lot. Houses in Hampton Park are set back a moderate distance from the sidewalk to provide for a front yard. Side yard setbacks provide the spacing between buildings. Although setback and spacing can vary somewhat from block to block, they are generally consistent to provide continuity and rhythm within the neighborhood. Houses are oriented to face the street, further reinforcing neighborhood patterns.

C. RELATE THE SETBACK, ORIENTATION AND SPACING OF NEW CONSTRUCTION TO THAT OF EXISTING BUILDINGS.

- > Align new construction with the setback established by adjacent houses while conforming to zoning requirements. This will include alignment of the front elevation and porch face.
- > Establish an average if adjacent houses do not follow a consistent setback.
- > Maintain average side yard setbacks based on adjacent houses and adhering to applicable zoning regulations.
- > Orient the primary facade to the major street onto which the lot faces.

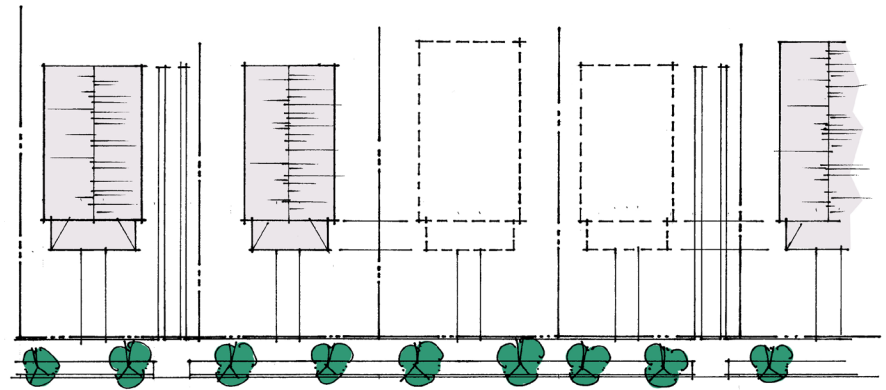

Compatible new construction aligns with the front elevation and porch setbacks established by adjacent houses.

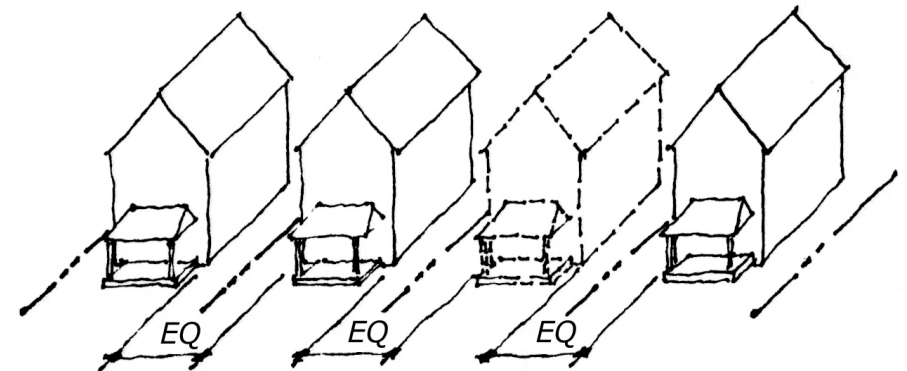

This compatible new construction maintains the average side setback and spacing established by adjacent houses.

SIZE, SCALE AND MASSING

In Hampton Park, building heights range from one story to two-and-one-half stories. These slight variations in building size add character and visual interest to the district. Most houses occupy narrow lots, are simple and rectangular in form, and are vertical rather than horizontal in their expression. The relationship of a new building to adjacent historic buildings in terms of size and scale establishes its compatibility within the block or district. Buildings that deviate from the predominant size and scale of other buildings on the street can negatively affect the district if sensitive massing and transitions are not part of their design.

D. DEVELOP RESPECTFUL RELATIONSHIPS IN TERMS OF SIZE, SCALE AND MASSING TO ADJACENT HISTORIC BUILDINGS.

- > Use an appropriate form and massing for new construction that relates to the majority of surrounding buildings.
- > Reflect the widths of adjacent buildings in new construction. Generally, new construction should not differ in width by more than 10 percent from the typical buildings on the street.
- > Reflect the heights of adjacent houses in new construction. Generally, new construction should not differ in height by more than 10 percent from the typical buildings on the street.
- > Use floor to ceiling heights that are compatible with adjacent buildings to maintain existing building proportions on the block. Appropriate floor to ceiling heights for new construction are eight to ten feet.
- > Create visual interest at the ground level to emphasize the human scale of the building by incorporating functional elements like traditional front porches.



The one-story infill in the example above does not relate to the predominant heights or widths of surrounding buildings on the block.

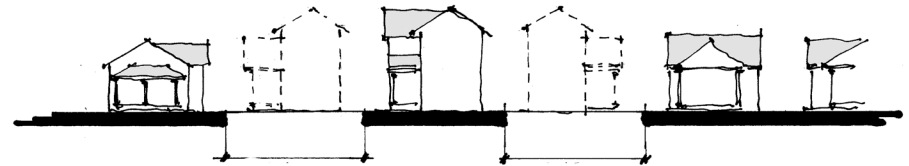

A one-story porch can help relate a new two-story house to a neighboring one-story house.

MORE INFORMATION

DEFINITIONS

Size: Determined by the two dimensional measurement of the height and width.

Scale: Refers to the relationship between two or more objects. In architecture, scale can refer to the relationship of the human form to a building or the relationship of one building to another.

Massing: Perception of the general shape and form as well as the size of a building.

ROOF FORM

The roof form plays an important role in defining the overall form of a house. The most common roof forms in Hampton Park are variations of gable and hipped forms, with the ridgeline parallel to the street. A variety of roof forms provides visual interest to the historic district.

E. CHOOSE ROOF FORMS FOR NEW CONSTRUCTION THAT ARE SIMILAR TO ADJACENT HISTORIC EXAMPLES.

F. REFLECT THE ROOF PITCHES OF ADJACENT HISTORIC HOUSES IN THE ROOF PITCH OF NEW CONSTRUCTION.

- > Use a minimum roof pitch of 6:12 and a maximum roof pitch of 12:12 to facilitate drainage. Intersecting roofs should have the same pitch as the main roof.
- > Devote a minimum of 8 inches for eave and gable overhangs.

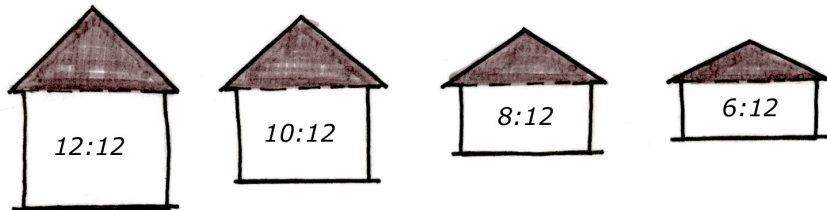

Roof pitch in the historic district should range between 6:12 and 12:12.



Gable



Hipped with Intersecting Gables



Hipped



Intersecting Gable

The most common roof forms in the Hampton Park Historic District are gable, hipped, or a combination of the two.

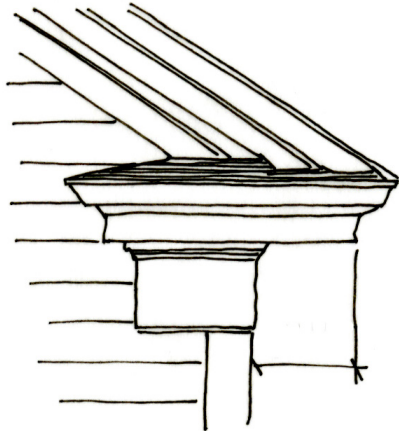

Houses in the historic district typically feature an eave overhang.

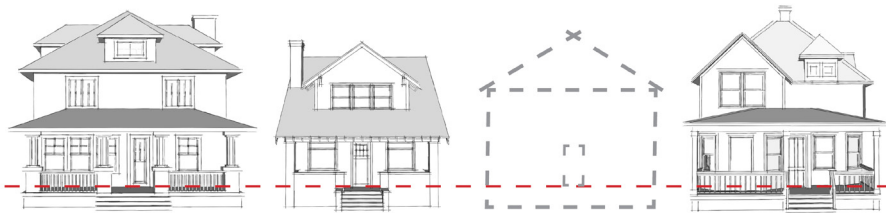

Align foundation height of new construction with adjacent houses to maintain façade proportions along the block. A foundation that is too low or too high can make a new house appear out of scale.

FOUNDATION

Historic residential buildings in Hampton Park are built on raised foundations, with heights varying from one foot above grade to three feet above grade on the front elevation. Foundation heights may increase several more feet on secondary and rear elevations due to grade changes. Most foundations in the historic district are brick. Foundations serve functional and aesthetic purposes and incorporating the feature helps to tie new construction in with surrounding buildings.

G. RESPECT THE HEIGHT AND CONTRAST OF MATERIALS OF FOUNDATIONS ON ADJACENT HISTORIC BUILDINGS.

- > Align foundation height of new construction with adjacent houses.
- > Ensure foundation height is within 10 percent of the average foundation height of adjacent houses.
- > Build a new foundation at least one foot above grade on the primary elevation.
- > Differentiate the foundation level from the main wall plane through a change in material or texture.

PORCHES

The front porch serves as the focal point of a house and provides an area for people to gather and socialize. It also serves as an important transition between the interior and exterior of the residence, as well as from the house to the public sidewalk. In Hampton Park, almost all houses have some type of porch on the primary or street elevation. Varying in size, some porches extend across the entire width of the façade while others only shelter the entrance. Most are one story in height, with two-story porches being rare. Incorporating porches into new residential construction reinforces the connection with historic houses on the street and can help to reduce the perceived scale of the building.

H. INCORPORATE A PORCH ON THE PRIMARY ELEVATION OF NEW RESIDENTIAL CONSTRUCTION.

- > Ensure that the design, placement, and height of a porch is in accordance with those of adjacent buildings on the block.
- > Design a porch to have a depth of at least six feet, although 8 to 10 feet is recommended to create a usable space.
- > Use simple round or square columns of uniform shape and style with a base and a cap. Aim for a minimum diameter of six inches and a maximum diameter of ten inches.
- > Use simple square balusters with appropriate proportions and spacing.
- > Frame the underside of the porch with lattice between pier supports and under the skirt board.
- > Use enclosed stair risers for the front porch stairs.
- > Design the porch roof with a pitch equal or less than that of the main roof.

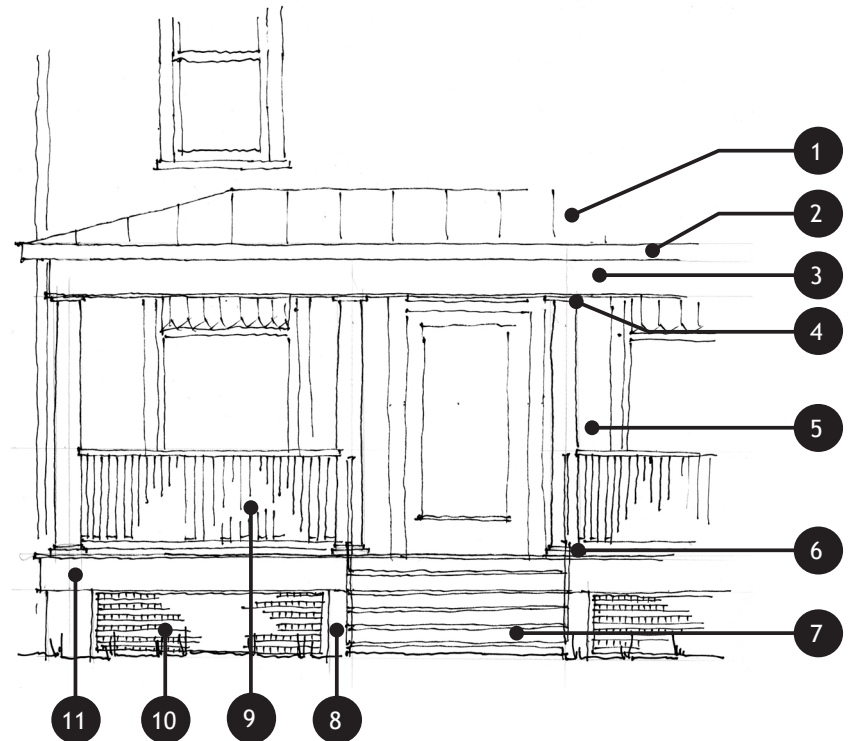

- | | |
|-------------------|------------------------|
| 1. Porch Roof | 7. Closed-riser Stairs |
| 2. Fascia | 8. Brick Pier |
| 3. Entablature | 9. Balusters |
| 4. Column Capital | 10. Wood Lattice |
| 5. Column Shaft | 11. Skirt Board |
| 6. Column Base | |

Gain an understanding of traditional components of a porch.

WINDOW AND DOOR PATTERNS

Windows and doors are among the most highly visible features on a house. Their size, proportion, pattern, and character help give a building its individual style and character. Most residences have a higher proportion of solid wall surface than window and door openings. Window openings are generally uniform in size, spacing and alignment and are typically vertically proportioned. Primary entrances on houses in the district are oriented to face the predominant street.

I. ARRANGE WINDOWS AND DOORS TO REFLECT THE TRADITIONAL SIZE AND PROPORTION OF THOSE ON ADJACENT HISTORIC HOUSES.

- > Keep new doors and window openings within 10 percent of the height and width of those on adjacent historic buildings.
- > Proportion windows to be approximately twice as tall as they are wide.
- > Use commercial-style windows and doors that have proportions similar to those of adjacent buildings in new non-residential construction in the district.

J. ARRANGE WINDOWS AND DOORS TO REFLECT THE SPACING, RHYTHM AND ALIGNMENT OF OTHERS IN THE DISTRICT.

- > Locate the primary entrance of a building on the front elevation, oriented to the most prominent street that borders the property.
- > Align windows vertically and horizontally.

K. RELATE THE RATIO OF SOLID WALLS TO VOIDS (WINDOWS AND DOORS) OF NEW HOUSES TO THAT OF ADJACENT HISTORIC HOUSES.

- > Avoid blank walls by covering a minimum of 20 percent of wall surface between the eaves and the foundation with window and door openings.
- > Avoid large expanses of glass or solid wall that convey a contemporary appearance.

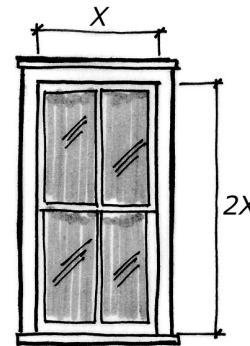

Windows in the district are traditionally taller than they are wide.

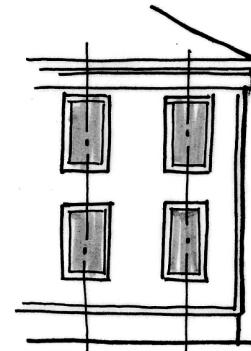

All windows on the same floor should be the same height and horizontally aligned. Align second floor windows vertically with first floor windows.

L. USE TRADITIONAL STYLES FOUND IN THE DISTRICT AS THE BASIS FOR NEW DOORS AND WINDOWS.

- > Incorporate glazing, sidelights, and a transom into the designs of new entrances.
- > Use a pane configuration for windows that is compatible with other houses in the district and that is consistent with the style of the house.
- > Avoid openings that are flush with the exterior wall. Openings are traditionally recessed on masonry buildings and have a raised surround on frame buildings.
- > Scale shutters to fit the window opening and only use them when they are in keeping with the style of the house.

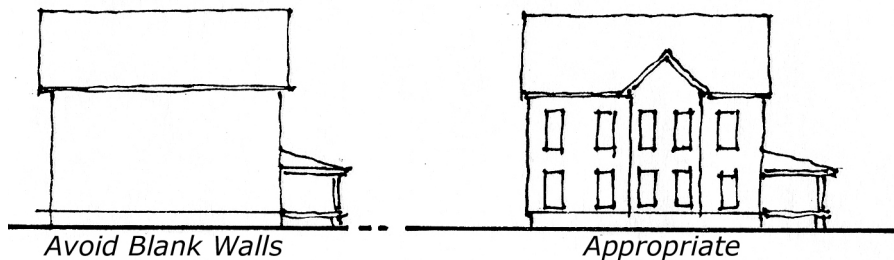

Respect the traditional relationship of window to wall area in the district and avoid blank walls.

ARCHITECTURAL DETAIL AND ORNAMENTATION

In Hampton Park, the level of architectural detail and ornamentation varies depending on the style and period of a building. Residential buildings in the district feature decoration such as cornices, exposed rafter tails, window and door trim, and patterned masonry. Successful new construction does not attempt to reproduce historic detailing, but will rather reinterpret traditional decorative features in a fresh, contemporary manner.

M. REINTERPRET TRADITIONAL DECORATIVE ELEMENTS IN A CONTEMPORARY MANNER.

- > Incorporate simplified architectural features that reflect, but do not duplicate, similar features found on existing historic buildings in the district.
- > Concentrate architectural detail in areas that traditionally featured detail, such as floor transitions, window surrounds, and cornices or pediments.
- > Use detail that is three dimensional to add visual interest and texture to the façade.

MATERIALS AND COLOR

Houses in Hampton Park are primarily of frame and brick construction, with frame predominating. Dark colored roofs, wood trim, brick chimneys, and raised brick foundations are also characteristic of most historic residences in the district. These traditional materials are most appropriate for new construction in Hampton Park.

N. CHOOSE HIGH QUALITY AND DURABLE MATERIALS THAT ARE VISUALLY COMPATIBLE WITH AND COMPLEMENTARY TO THE ARCHITECTURAL CHARACTER OF THE DISTRICT AND SURROUNDING BUILDINGS.

- > Use brick or concrete for the foundation material. If concrete block is used, it should be painted or covered with stucco.
- > Use wood or brick for exterior wall cladding of new construction or additions.
- > Employ a uniform primary wall material on all sides of the building. Use of a limited number of different materials may be appropriate if a building is broken up into separate masses.
- > Use horizontally oriented weatherboard, clapboard, or shiplap siding for frame buildings.
- > Consider cementitious products, including shingles and siding, for new frame construction if applied in a traditional pattern. Use the smooth side rather than the grained surface and apply with a reveal that is consistent with historic precedents in the district.

- > Use masonry units that are compatible in color, texture and size to those on adjacent buildings. Mortar joints should be compatible in width, profile, and color.
- > Use traditional materials for trim, windows, doors, porches and other decorative features. Contemporary materials that are compatible with historic materials may be acceptable if the material conveys the visual qualities of traditional materials.
- > Consider traditional standing-seam metal or asphalt shingles. Pre-coated terne products may be appropriate if manufactured in traditional widths and if installed with standing seams.
- > Use brick as the chimney material to be compatible with historic houses in the district.

O. SELECT A COORDINATED COLOR PALETTE INFORMED BY HISTORIC PRECEDENT AND COMPATIBLE WITH ADJACENT BUILDINGS AND THE DISTRICT AS A WHOLE.

ADDITIONS

While older homes are admired for their character and charm, potential buyers often opt for new construction with the modern amenities they have come to expect. However, a sensitive addition to a historic home can provide needed extra space and modern amenities. Nevertheless, insensitively designed additions can radically alter the historic appearance of the building and destroy important features. Careful design and location of new additions can complement rather than detract from the character of a historic building and the district as a whole.

P. DISTINGUISH A NEW ADDITION FROM THE HISTORIC BUILDING WITH A SIMPLE AND UNOBTRUSIVE DESIGN.

- > Design an addition to be subordinate to the existing building in size, design and detailing.
- > Locate a new addition on the rear elevation where not highly visible from the public right of way. Side additions subordinate to the original house may be appropriate in some situations, depending on the lot configuration and architectural style of the house.
- > Keep the addition height lower and the width narrower than that of the original house. Set back side additions at least two feet from the front plane of the house.
- > Ensure the design is distinct from the original house but still compatible. Avoid the exact replication of the original house.
- > Include simplified architectural features derived from similar features on the historic building.
- > Chose a roof form that complements that of the original building. Keep the roof pitch similar to the original building, but proportional to the size of the addition.

- > Base the size, rhythm and alignment of the window and door openings on those of the historic building.
- > Ensure that colors and materials are harmonious with the materials of the historic building.

Q. AVOID OBSCURING OR DESTROYING IMPORTANT FEATURES OR MATERIALS OF THE EXISTING BUILDING WHEN CONSTRUCTING AN ADDITION.

R. DESIGN AND CONSTRUCT AN ADDITION SO IF REMOVED IN THE FUTURE THE BASIC FORM AND CHARACTER OF THE ORIGINAL BUILDING REMAIN INTACT.

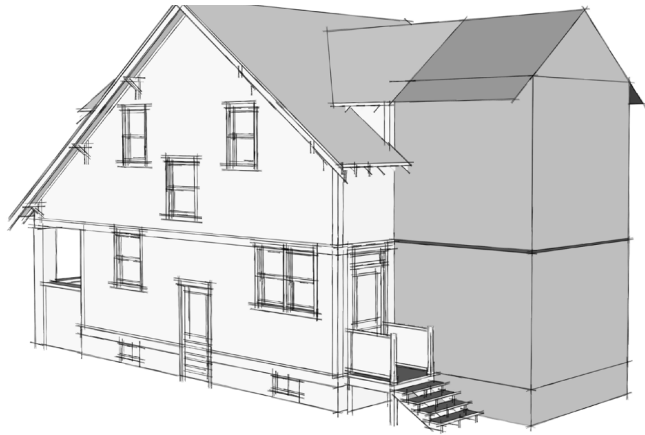

Rear additions are least visible from the street and have the lowest impact on architectural features, since the rear elevation is typically simpler than the front.

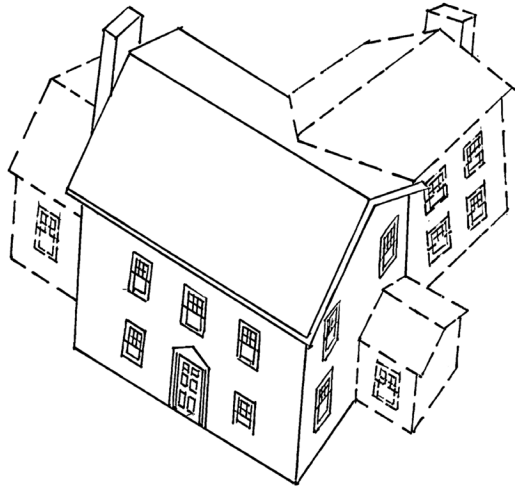

Side additions can be appropriate depending on lot configuration and architectural style. The side addition shown in this example is subordinate to the original Colonial Revival style house, set back from the front plane of the façade.



This compatible rear addition is subordinate to the original house with its side setbacks and successfully continues the size, rhythm and alignment of the window openings.

MORE INFORMATION

Preservation Brief #14

New Exterior Additions to Historic Buildings: Preservation Concerns

PAGE LEFT INTENTIONALLY BLANK

PAGE LEFT INTENTIONALLY BLANK

7

RELOCATION & DEMOLITION

In a historic district, the cumulative value of all of the buildings is greater than the sum of its parts. Individual buildings, which may not be architecturally significant in themselves, are valuable as they contribute to the cumulative aesthetic and architectural character of the district. Historic districts rely on the physical Integrity of continuity and cohesiveness to achieve this cumulative effect. Consequently, the loss of any contributing building in a district—whether by demolition or relocation—will diminish the physical integrity necessary to convey the district’s architectural character and historic significance. Therefore, the demolition or relocation of contributing buildings in a historic district should be avoided.

PAGE LEFT INTENTIONALLY BLANK

7.1 RELOCATION

The physical location of a building, including its immediate site characteristics, as well as the general setting of the surrounding buildings and streetscape, contributes to its architectural character. In most cases, the relocation of a historic building should be avoided as it will have a negative impact on the building and the surrounding historic district. For this reason, the relocation of historic buildings within a historic district should be considered carefully and only when all other preservation options have been thoroughly explored. In cases where the building is threatened with demolition or its historic context of site and surroundings has been significantly compromised, relocation may be the best option. In such cases, the proposed new location must be compatible with the historic character of the building in terms of both the site and the general setting.

A. RETAIN A CONTRIBUTING BUILDING ON ITS PRESENT SITE.

- > Relocate a contributing building only after examining all alternatives to retention.
- > Move or relocate a contributing building only if it is threatened by imminent demolition or if its historic context of site and setting has been significantly compromised.
- > Move or relocate a building that does not contribute to the architectural and historic character of the district if its removal would improve the visual appearance for the district.

B. SELECT A NEW SITE WITH A SIMILAR SETTING AS THE ORIGINAL LOCATION.

- > Choose a new site that is similar to the original site in terms of size, topography and vegetation.
- > Determine if the building will be architecturally compatible with the neighboring buildings in terms of its style, scale, height, materials and setback.
- > Determine if site features historically associated with the building, including fencing, retaining walls, sidewalks, driveways or secondary structures, can be accommodated at the new location.

C. IDENTIFY THE RELOCATED BUILDING WITH A PLAQUE.

- > Include the date and location of the original construction, as well as its relocation date.
- > Place the plaque in a location visible from the public right-of-way.

SCENARIOS FOR RELOCATION

- > The relocation of a historic building from one location to another within a historic district;
- > The relocation of a historic building located outside of the district to a site within the district; or
- > The relocation of a historic building within a district to a new site outside of the district.

Regardless of the scenario, the appropriateness of relocating a historic building depends on the status of the building—in terms of threat of demolition or its integrity of site and setting—as well as the suitability of the proposed new location.

APPLICATION MATERIALS

A Certificate of Appropriateness is required for the relocation of any building within a historic district. Applications to relocate a building should include the following:

- ✓ An explanation of the current condition and imminent threat to the historic building.
- ✓ Photographs of the building and its existing site, including all site features and general setting of streetscape and neighboring buildings.
- ✓ Photographs of the proposed new site and the general setting, including streetscape and neighboring buildings.
- ✓ Site plans of the existing location and the proposed new location, including building footprint, setback, landscaping and associated site features such as sidewalks, driveways, fencing, and secondary structures.
- ✓ A detailed plan by a qualified expert in moving historic buildings outlining the steps to be taken to successfully relocate the building.

7.2 DEMOLITION

Every effort should be made to avoid the demolition of contributing buildings in a historic district, as once a building is demolished, it is gone forever and the integrity of the district is diminished. In some cases, demolition of a building may be necessitated for the safety and welfare of the public. Demolition, however, should only be considered after all reasonable alternatives, including alternative uses, sale of the property, or relocation have been evaluated and exhausted. In any case, the cost of demolition must be taken into account when considering the feasibility of preserving a building rather than demolishing it. The HPDRC may impose a 120-day waiting period to allow for the thorough consideration of the application and the exploration of all alternatives to demolition.

A. DEMOLISH A HISTORIC BUILDING ONLY AFTER ALL ALTERNATIVES HAVE BEEN EXHAUSTED.

- > Provide an explanation of alternatives that were explored and the reasons why they were not feasible options.
- > Prepare a detailed plan for the development of the site that includes a budget for both the demolition and the new construction, as well as a timetable.
- > Document the building prior to demolition to include measured drawings, photographs and a detailed history of the property.

REQUIREMENTS FOR DEMOLITION

DEMOLITION MAY ONLY BE APPROVED IF ONE OR MORE OF THE FOLLOWING CONDITIONS ARE MET:

Public Safety Hazard:

When the local building official has determined that the physical condition of the building constitutes a hazard to the safety and welfare of the public.

Loss of Architectural Integrity:

When a building has lost its original architectural integrity of location, setting, design, materials, workmanship, feeling and association to a point that it no longer contributes to the historic character of the district.

Loss of Structural Integrity:

When a building has deteriorated and is structurally unstable. This condition must be demonstrated in a report by a licensed architect or structural engineer that fully documents the building's physical condition, provides a reasonable cost estimate for the necessary repairs, and justifies why such repairs are not feasible.

Economic Hardship:

When economic hardship has been demonstrated and proven by the property owner and such hardship is accepted by the HPDRC. A detailed report should be provided that includes a reasonable estimate of rehabilitation costs and evidence that the potential value of the property cannot produce a financial return on such investment.

PAGE LEFT INTENTIONALLY BLANK